

Triton Series

U.V. Disinfection

INSTALLATION & OPERATION MANUAL

This manual covers installation, operation and maintenance requirements for Neptune U.V. Disinfection Systems.

Model - TRI-8, TRI-12, TRI-20

(During normal operation, the Green LED will flash every 5 - 10 seconds.)

It is important that those responsible for the installation of this equipment, as well as the owner / operator, read this manual and carefully follow the instructions and guidelines.



Water Treatment & Accessories, LLC
2045 Rockvale Road
Lancaster, PA 17062
ph: (717) 295 - 9339
fax: (717) 396 - 0364

SAFETY INSTRUCTIONS

WARNING - to guard against injury, basic safety precautions should be observed, including the following:

1. **READ AND FOLLOW ALL SAFETY INSTRUCTIONS.**
2. **DANGER** - To avoid possible electric shock, special care should be taken since water is present near electrical equipment. Unless a situation is encountered that is explicitly addressed by the provided maintenance and troubleshooting sections, do not attempt repairs yourself, refer to an authorized service facility.
3. Carefully examine the disinfection system after installation. It should not be plugged in if there is water on parts not intended to be wet.
4. Do not operate the disinfection system if it has a damaged power cord or plug, if it is malfunctioning or if it is dropped or damaged in any manner.
5. Always disconnect water flow and unplug the disinfection system before performing cleaning or maintenance activities. Never yank the power cord to remove it from an outlet. Grasp the plug and pull to disconnect.
6. Do not use this disinfection system for other than the intended use (potable water applications.) The use of attachments not approved, recommended or sold by the manufacturer / distributor may cause an unsafe condition.
7. Intended for indoor use. Do not install this disinfection system where it will be exposed to the weather. Do not store this disinfection system where it will be exposed to temperatures below freezing unless all the water has been drained from it and the water supply has been disconnected.
8. Read and observe all the important notices and warnings on the water disinfection system.
9. If an extension cord is necessary, a cord with a proper rating should be used. A cord rated for less Amperes or Watts than the disinfection system rating may over heat. Care should be taken to arrange the cord so that it will not be tripped over or accidentally pulled from the outlet.

1. **SAVE THESE INSTRUCTIONS.**

WARNING: The light given off by this unit can cause serious burns to unprotected eyes and skin. Never look directly at a lit UV lamp. When performing any work on the UV Disinfection System, always unplug the unit first. Never operate the UV system while the lamp is outside of the UV chamber.

WARNING: The UV lamp inside of the disinfection system is rated at an effective life of approximately 9,000 hours. To ensure continuous water treatment, replace the UV lamp annually with the appropriate Aqua Treatment Services UV lamp. Failure to comply may present a fire hazard.

FUNCTION:

The function of this ultraviolet disinfection unit is to provide in excess of 99% reduction of all water borne pathogenic (disease causing) bacteria.

Model Triton series have a number code designation correspondent to the maximum gpm (gallons per minute) flow rate of the unit. I.E.- TRI-8 has a maximum flow capacity of 8 gpm.

Applications:

Ultraviolet Germicidal Disinfection

Neptune Ultraviolet Disinfection Units are designed to destroy micro-organisms in water supplies. The Ultraviolet lamp peak radiation of 254 nanometer wavelength (nm) destroys or inactivates the D.N.A. (deoxyribonucleic acid) which absorbs the Ultraviolet radiation. Triton Germicidal Disinfection units meet minimum dosages of 30,000 microwatt second per square centimeter.

MAXIMUM CONCENTRATION LEVELS BEFORE ULTRAVIOLET:

Turbidity.....	5 NTU	Hardness.....	7 gpg
Color.....	None	Iron.....	0.3 ppm
Manganese.....	0.05 ppm	pH.....	6.5 - 9.5ppm

Important Note - Pre-filtration equipment may be required if these parameters cannot be maintained. Flow rate must not exceed rated capacity of the unit.

DESCRIPTION OF EQUIPMENT:

The Triton series has an unique design with an ultraviolet germicidal lamp housed within a single quartz sleeve surrounded by a stainless steel pressure chamber. The chamber is fabricated out of 304 Stainless Steel.

These units come with an ultraviolet lamp designed with four pins at one end.

The quartz sleeve is intended to be placed through the disinfection chamber and will slightly protrude through the threaded nipple. The ultraviolet lamp is placed within this quartz sleeve. The U.V. light shines through this specially designed hard quartz sleeve for maximum disinfection efficiency to meet the requirements for bacteria reduction in potable water.

The inlet/outlet are located on one side of the chamber and may be interchanged as to designation dependent upon installation. A Site Port is provided for safe and easy view of operation. A box is secured to the wall and the chamber is held in place by tightening the lock nut to both mounting box and chamber.

GENERAL CONSIDERATIONS FOR ALL DISINFECTION UNITS:

1. When installing the equipment, it is necessary that the unit be isolated from vibration, heavy equipment, and poorly connected piping.
2. Incoming water temperature to the unit should not exceed 35° minimum to 110° maximum degrees Fahrenheit.
3. The operating pressure should not exceed 100 psi.
4. Before putting the unit into final operation follow sanitation procedures as outlined in this manual for proper disinfection. Sanitizing all discharge piping and fittings with household bleach from disinfection unit to point of use removes existing contaminants and gives the unit a “clean start.” Be sure to rinse with U.V. treated water.
5. A proper flow control must be used to insure only the designated flow through the unit.

GENERAL PRECAUTIONS TO BE FOLLOWED AT ALL TIMES:

1. Always disconnect electrical power to any U.V. unit before servicing.
2. Under no circumstances should personnel look at a U.V. lamp in operation
(EXCEPT through an external Site Port lens located on the outside of the unit).
3. U.V. disinfection units must always be properly grounded.

INSTALLATION:

The Triton series are always placed after the pressure tank and any other type of treatment devices (i.e. softeners, filters).

These units are normally installed in a vertical position in an enclosed area with good ventilation. Allow clearance of at least the unit's length at one end for quartz sleeve and bulb replacement. Two (2) anchor bolt holes are provided for proper wall support. Use wall plugs with screws for sufficient support (not included). A lock nut secures the mounting box to the U.V. chamber.

If your piping system is subject to impulse pressure resulting in a “water hammer” condition, a surge tank or other means must be provided to remove this condition; otherwise, this extreme shock pressure condition may rupture or fracture the quartz sleeve.

Make all plumbing connections to allow for ease of service. Be sure to follow all local plumbing codes and U.V. restriction requirements where specified by local authorities.

The electrical control box is vented to allow proper air ventilation to components. For outdoor applications install a protective rain guard shield (contact your UV supplier for part number) to prevent water from direct contact with the control box. The rain guard is not necessary for indoor applications.

STEP BY STEP INSTALLATION:

1. Turn off the water before cutting into the water line.
2. Assess the installation (i.e. type of pipe, size of lines, etc.) and obtain necessary plumbing fittings for installation. Inlets and outlets on 8 gpm units are 3/4" MNPT. Use Teflon tape on all threaded connections and avoid over tightening.

Note: The flow control is a press in type. Each unit has a 3/4" MNPT inlet/outlet machined so the press in flow control can be easily inserted into whichever port you select for the inlet. Make sure the rubber part of the flow control is facing outward from the port selected. Simply hand press or slightly tap in the flow control until it sits on the inside ledge of the machined port.

3. Using the mounting box provided, secure unit to wall, or other surface. Make sure to allow enough room to install, replace, and clean the quartz sleeve and bulb. Installing a water shut-off valve before and after the unit is recommended to make servicing easy.
4. After mounting, install quartz sleeve, O-Ring, and bulb per instructions. Turn on the water slowly, check for leaks, and repair as needed prior to full service operation.
5. After the unit is full of water, plug it into a grounded 110V outlet. Observe operation through the safety Site Port. The lamp will show a bright blue glow. If any problems are noted, consult trouble shooting guide.

GENERAL INSTALLATION DIAGRAM

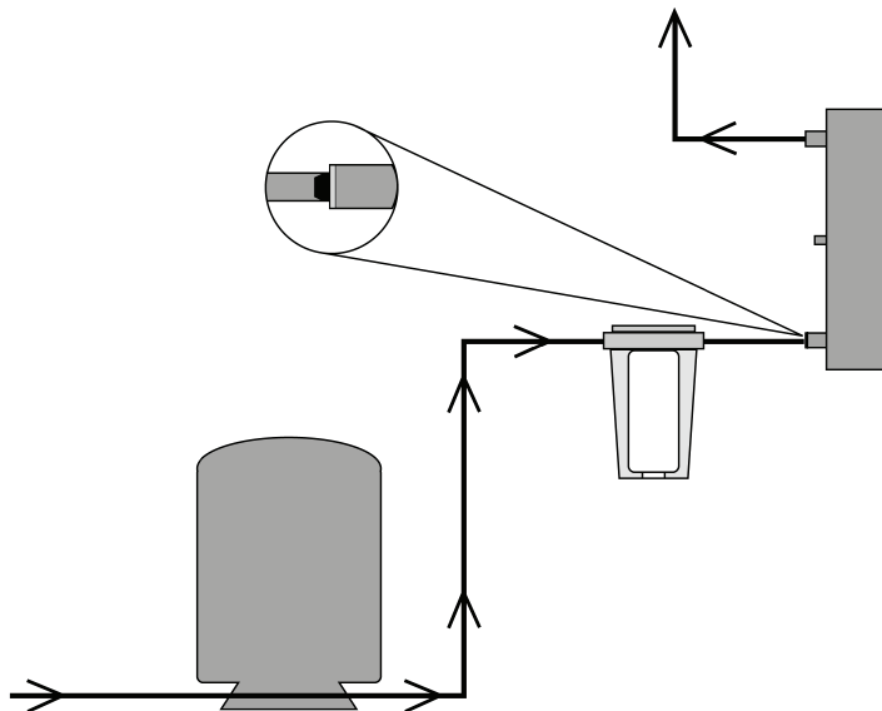

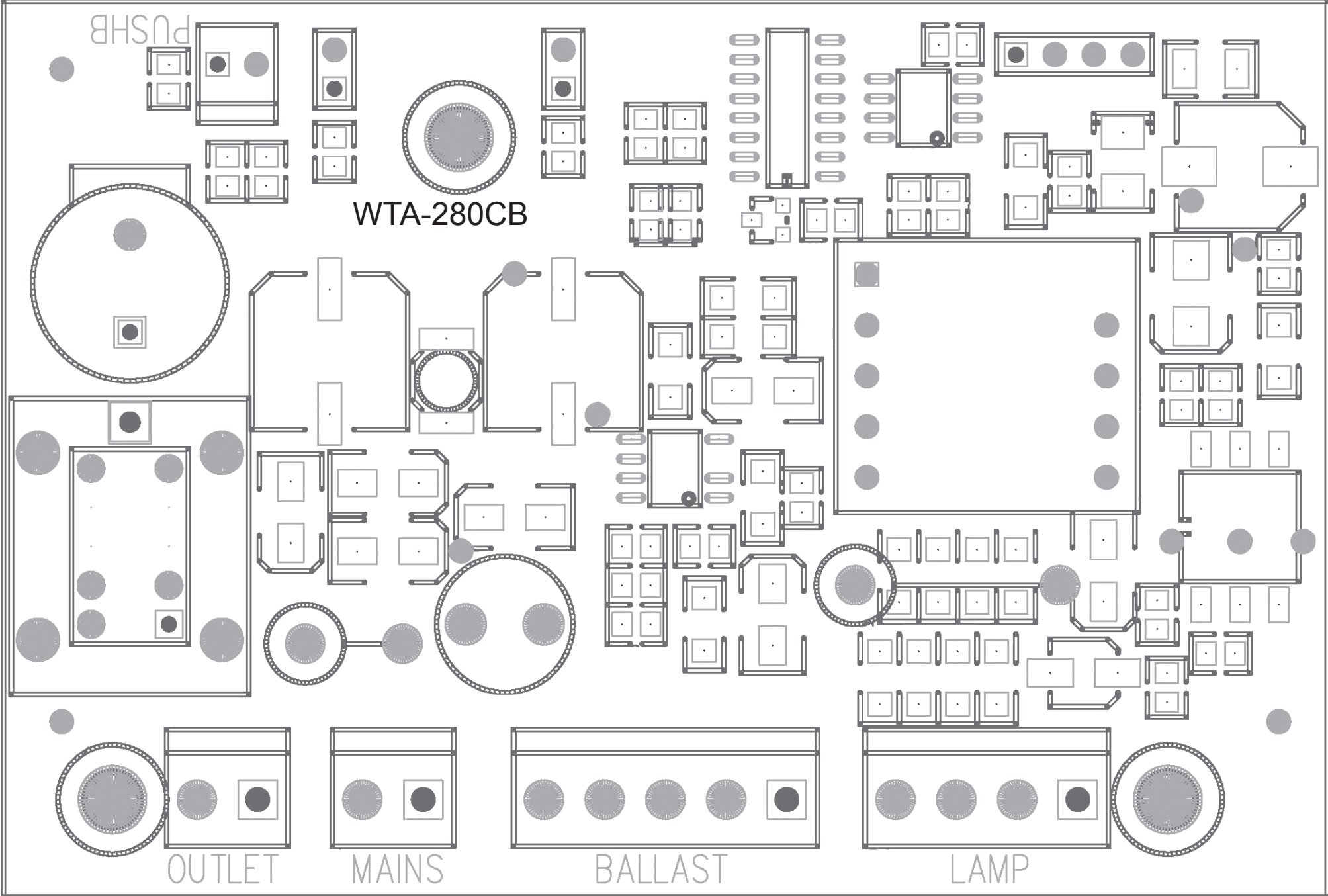

OPERATING INSTRUCTIONS

Your UV System is equipped with the ATS-280CB UV Lamp Detector and Timer circuit board which is designed to provide a continuous monitoring system of the UV lamp operational status. This solid state electronic circuit board provides the latest in UV lamp monitoring technology.

UV LAMP / CONTROL BOX START UP PROCEDURE - (4 Step Process)

1. Make sure the UV lamp is inserted per instructions into the quartz sleeve and UV chamber. Then plug the UV lamp into the lamp connector.
2. Plug the electrical control box into a 120volt wall plug outlet.
3. Upon start up the UV lamp Detector and Timer circuit board will perform a self diagnostic test. **When power is applied the UV lamp will go on and a circuit board output check is performed as follows:**
 - Quick Beep
 - Green LED on, then off
 - Red LED on, then off
 - Solenoid / Relay connection on, then off
 - Pause with beeps
 - Green LED on = System Check OK, UV System is operational.
4. Set the 1 Year Lamp Timer – WITH NEW UV LAMP –

Make sure the control box is plugged into the wall outlet and the UV lamp is on. Press and hold the reset push button. A tone that descends in frequency once per second will be heard. Hold the reset button down for approximately 5-8 seconds until you hear a continuous tone. At this point release the button. The 1 year lamp timer has just been reset.

UV lamp Detector and Timer circuit board Lamp Operation and Alarm features:

- UV System OK – Green LED will flash every 5 - 10 seconds.
- 30 Days remaining on Lamp Life – Flashing Yellow LED with an intermittent audible tone.
- End of Lamp Life- Flashing Red LED with an intermittent audible tone.
- Lamp Out- Continuous Red LED with a continuous audible tone.
- If your UV System has a 120Vac Normally Closed Solenoid Valve or Remote Alarm connected to the UV Unit plug-in connection, this will activate at End of Lamp Life or Lamp Out alarm conditions.

To Silence the Audible Alarm with Snooze Button:

1. 30 Days remaining on Lamp Life Alarm - Push reset button – Silences the audible tone for two weeks while the Yellow Led continues to Flash. (You can Silence audible alarm 2 times Max.) You have up to 30 days to replace the lamp. **Service Unit - Replace the UV Lamp within 30 Days.**
2. End of Lamp Life Alarm - Push reset button- Silences the audible tone for one week while the RED LED continues to flash. (You can Silence audible alarm 4 times Max.)
Service Unit Immediately - Replace the UV Lamp.
3. Lamp Out Alarm- Push reset button- Silences the audible tone for one week while the continuous Red LED stays on. (You can Silence audible alarm 1 time only.)
Service Unit Immediately - Replace the UV Lamp.

To Find out how many Months are left on the Lamp Timer - Push the reset button for 1-2 seconds then release. After an initial sound there will be a pause followed by beeping and a flashing LED. The number of beeps corresponds to the number of months left on the lamp life.

To Reset 1 Year Lamp Timer – WHEN REPLACING THE UV LAMP. Unplug the control box from the wall outlet. Unplug the UV lamp from the Lamp connector. Replace with a new UV Lamp. Make sure the control box is plugged into the wall outlet and the UV lamp is on. Press and hold the reset push button. A tone that descends in frequency once per second will be heard. Hold the reset button down for approximately 5-8 seconds until you hear a continuous tone. At this point release the button. The 1 year timer has just been reset.

LAMP STATUS INDICATOR / UV LAMP ADVISOR:

LED COLOR	AUDIBLE ALARM	UNIT STATUS
GREEN	NONE	OK
FLASHING YELLOW	INTERMITTENT TONE	REPLACE LAMP WITHIN 30 DAYS.
FLASHING RED	INTERMITTENT TONE	LAMP HAS EXCEEDED 1 YEAR OF OPERATION, REPLACE LAMPS & RESET.
CONTINUOUS RED	CONTINUOUS TONE	UV LAMP IS NOT LIT.

NOTE: During normal operation, the Green LED will flash every 5 - 10 seconds.

Please contact your local dealer for replacement UV lamps.

Refer servicing to qualified service personnel.

QUARTZ SLEEVE:

Installation of the Quartz Sleeve:

Always handle quartz sleeves carefully to prevent breaking or chipping. The quartz sleeves are to be clean and free of fingerprints before installing.

Remove the compression nut. Install the quartz sleeve through the stainless steel threaded nipple allowing an equal amount to extend beyond each nipple. Install the O-Ring down the top of the nipple. Avoid riding the O-Ring on any threaded part of the nipple. Hand-tighten each compression nut to form a compression seal around the quartz sleeve. **Avoid overtightening** the nuts, which may cause a fracture on the end of the quartz sleeve. Under normal operation conditions, hand-tightening will provide a 100 psi seal. Do not use any devices to tighten end nuts. Repeat this procedure at the opposite end of the chamber.

After you have tightened the compression nut and all other plumbing connections, open the outlet valve. Slowly open the inlet valve and flush out all remaining air. Then close the outlet valve and slowly open the inlet valve fully. Check the unit for leaks. If you find a leak at the compression nut, tighten the nut further. If the leak continues, drain the unit and inspect the quartz O-Ring and quartz sleeve for proper seal. Once you complete checking the unit, reassemble O-Ring and tighten gland nut. Repressurize the unit and check again.

REQUIREMENTS FOR CLEANING THE QUARTZ SLEEVE:

As water passes through the U.V., minerals, debris and other matter in the water may deposit onto the quartz sleeve. After sufficient film has formed on the quartz sleeve, the ability of the ultraviolet germicidal rays to pass through the quartz sleeve and into the water may be impaired. Therefore, it is necessary to determine a cleaning schedule for the quartz sleeve. The frequency will depend on the specific type of water conditions. If the water has been processed through deionization, reverse osmosis, or is distilled, cleaning may be required only once per year. If untreated water is used, the cleaning frequency will vary. A minimum of once yearly is standard recommendation for cleaning and lamp replacement. Contact your local dealer for scheduling this service. Your specific situation will vary the frequency time according to the water quality of the home or facility application.

QUARTZ SLEEVE CLEANING PROCEDURES:

To clean the quartz sleeve, turn off the water flow to the disinfection unit, turn power off, and disconnect the electrical service to the lamp pins. Carefully remove the U.V. lamp. Loosen the compression nuts with O-Rings and remove the quartz sleeve while draining the water from the chamber. The quartz sleeve may then be washed with a mild soap and hot water solution and rinsed clean with hot water. Should this be insufficient to clean the quartz sleeve, a mild acid may be used (i.e. vinegar). Be certain to follow all recommended safety and handling procedures on the acid container. It is important to handle the quartz sleeve with care to prevent breakage. Make certain that all finger prints are wiped clean before reinstalling (see installation of the quartz sleeve). Replace O-Rings [ATS8-544(1)] every time a quartz sleeve is cleaned or replaced.

U.V. LAMPS:

INSTALLATION OF THE ULTRAVIOLET LAMPS:

****DO NOT PUT POWER ON AT THIS TIME!****

CAUTION: Never look directly at a operating U.V. lamp operate a U.V. lamp outside the disinfection chamber.

Make sure unit is unplugged when installing or servicing ultraviolet lamp. Remove any paper tabs on the U.V. lamp and avoid allowing fingerprints and other debris to deposit. Carefully place the bulb inside the quartz sleeve leaving enough space to connect the socket connector to the lamp pins. Insert the protective polyurethane endcaps into the quartz open ends to secure the lamp(s) in place or reinstall brass dust covers.

ULTRAVIOLET LAMP MAINTENANCE REQUIREMENTS:

The U.V. lamp is rated for 9,000 hours of continuous use. After this period of time, the U.V. lamp has undergone a photochemical change. While the lamp will not normally be burned out, the lamp quartz may no longer emit the 254-nm shortwave U.V. to effectively kill bacteria. **Failure to replace the U.V. lamps every 9,000 hours may cause bacteriological breakthrough.** Should the use of the disinfection unit be intermittent, in no case should the U.V. lamp be used for more than 24 months regardless of the number of hours of operation due to normal shelf life degradation of the U.V. bulb. Changing the quartz sleeve should be done at the same time U.V. lamp replacement is scheduled.

It is recommended that your water supply be tested periodically (yearly) through your local health department or approved certified laboratory.

ELECTRICAL:

The Triton series are furnished with 6' line cord that will plug into a 110V outlet. Electrical receptacles must be properly grounded for safe operation. Improper grounding will void any warranty.

When possible use a separate breaker to minimize voltage fluctuations and avoid accidental shut off. After unit is installed and water is turned on, plug the unit into 110V wall receptacle. View lamp operation through safety Site Port lens. **NOTE: Avoid exposing your eyes to U.V. light.**

SANITATION PROCEDURE FOR INSTALLATION AND BULB REPLACEMENT:

HOW TO DISINFECT A WATER SYSTEM:

Every new well, or existing water supply system that has been disrupted for service or repair, should be disinfected before it is returned to use. Water in the well and storage tank should be treated with a strong chlorine solution to destroy disease organisms. All pipelines and fixtures in the distribution system should be rinsed and flushed with chlorinated water. Upon installation of a U.V. disinfection unit or yearly bulb replacement service, disinfection with chlorine to initially flush the system is recommended to assure line sanitation prior to U.V. start up.

The source of chlorine can be ordinary household liquid laundry bleach (about 5.25% available chlorine). The quantity required depends on the volume of water to be treated. The United States Environment Protection Agency (EPA) indicated that about 100 parts of chlorine, by weight, mixed in a million parts of water will destroy essentially all water-borne disease organisms. Table 1 shows the quantity of liquid bleach required to disinfect wells of various diameters and depths.

DISINFECTION PROCEDURE:

DRILLED WELLS: Remove the cap or seal from the casing and measure the depth of the water in the well, then refer to Table 1 to determine how much chlorine solution should be used. In some instances removing the seal to measure the water can be a difficult task, and it is easier to guess at the quantity of disinfectant needed than it is to make a more accurate determination (footnote, Table 1). As a general rule, it is better to use too much chlorine than too little. The disadvantage in doing so is that it will take longer for the taste and odor to leave the system.

Mix the required chlorine disinfectant with a few gallons of water in a plastic bucket and pour it into the well. If the seal has a removable vent, unscrew the pipe or plug and pour the disinfecting solution through the hole into the well. For maximum effectiveness, the chlorine must be mixed with the water in the well. This can be accomplished by connection a hose to a faucet beyond the pressure tank, and circulating the water from the tank back into the casing. After about 20 minutes, close this faucet, open another at the far end of the distribution line and let the water run until the odor of chlorine can be detected.

Close this faucet and repeat the procedure for each of the other outlets on the line until chlorinated water can be detected throughout the entire system. Keep this water in the pipeline for at least 6 hours, (preferably overnight) then start the pump and flush the system. Continue pumping until the odor of chlorine disappears. For U.V. installations or replacement bulb servicing, this can be shortened to 20 minute time.

LARGE DIAMETER WELLS: Dug or bored wells should be disinfected in the same way as a drilled one. Lower the water level as much as possible, remove the sand, silt and debris, and then treat with the chlorine solution. Mix thoroughly by circulating the water back into the well and use the hose to rinse the interior lining of the well. Do not try to disinfect an unprotected, unlined well because new seepage or surface contamination will flow into the water about as fast as you can disinfect it. Disinfect the pipeline distribution system as indicated for drilled wells.

SPRINGS AND CISTERNS: Mix about ½ cup of household bleach in 5 gallons of water and use this to scrub the walls of the spring box or holding tank. With a constant flow of fresh water from the spring, there is probably no way of detaining the chlorine solution in the reservoir for more than a few minutes. However, the chlorinated water should flow through the pipeline to disinfect the distribution system. Cisterns can be disinfected in the same way but a source of clean water will be needed to flush the dirty waste out of the system.

For additional information about how to protect wells and springs and keep them from becoming contaminated, call or visit your local Cooperative Extension office, or your nearest certified water treatment specialist.

TABLE 1 ** Quantity of solution mixed - 5.25% available chlorine (laundry bleach) for disinfecting wells, or 52,500 P.P.M..

WQA recommends 50mg/l or ppm chlorine concentration.

Formula - $C_2 \times V_2 / C_1 = V_1$

C_1 = Household Bleach (52,500 P.P.M.)

V_1 = Chlorine Amount Needed

C_2 = 50 mg/L V_2 = 80 gallons holding time

I.E. 50-ml/g X 80 gal = 4000/52,500 = .08 gallons of chlorine (5.25%)

.08 gal chlorine (5.35%) X 128 (oz/gal) = 10.24 oz (5.25%)

Dug Wells - 3 to 4 feet diameter - 4 cups per foot of water

Drilled Wells - 3 to 8 inch diameter - 1 cup per foot of water

TOO MUCH CHLORINE IS BETTER THAN TOO LITTLE:

** In situations where it is inconvenient to determine depth of water or diameter of a drilled well, a minimum of 1/2 gallon of household bleach may be used for wells up to 8 inches in diameter with estimated to be less than 80 feet deep; 1 gallon should be used for similar size wells with water deeper than 80 feet. In case of a well yielding more than 50 gallons per minute, special procedures are required. Seek the advice of a certified water treatment specialist.

Wait a day or two before you have another sample tested. **Do not take a sample for testing if the odor of chlorine is still present in water.**

REMEMBER - To make your water supply safe:

- Locate your well properly.
- Protect it from surface contamination.
- Test water periodically for coliform bacteria. (Home-yearly, Farm-2X yearly)
- Chlorinate, or filter and disinfect the water if necessary.

When installing an ultraviolet disinfection system, a prefilter with sump may serve as a source to sanitize the water lines only. For whole system disinfection follow procedure as outlined above.

Source: The Pennsylvania State University College of Agriculture Cooperative Extension.

How to Sanitize a Water System Using Well Sanitizer Pellets

Table 1

Well Diameter Inches	Weight of Pellets lbs. - oz.	Cups of Pellets	Number of Pellets
2	0 - 1.5	1/4	40
3	0 - 3.0	2/5	80
4	0 - 6.0	3/4	140
5	0 - 8.0	1	200
6	0 - 12.0	1-1/2	300
8	1 - 5.0	2-1/2	500
10	2 - 0	4	800
12	3 - 0	6	----
24	12 - 0	24	----
36	26 - 0	---	----

* To produce a 400 P.P.M. chlorine dosage

NOTE:

Pellets Weight = 1.14 gram each, 25 pellets/oz., 400 pellets/lb.
1 cup of pellets = 1/2 lb., or 200 pellets, or 8 oz.

To produce a 400 P.P.M. chlorine concentration, to sanitize a water system, use one-half (1/2) pound chlorination pellets for each 100 gallons of water in the system (1/2 lb/100 gal= 8 oz/100 gal= 200 pellets/ 100 gal= 1 cup pellets/100 gal). Table 1 shows how many pellets too use per 100 feet of water in various diameter wells.

DRILLED WELLS:

1. Remove the cap or seal from the casing and measure the depth of the water in the well, then refer to Table 1 to determine how many chlorine pellets should be used. In some instances removing the seal to measure the water can be a difficult task, and it is easier to estimate well and water depth from well log or other records.
2. Remove well cap and determine if there is an unobstructed path from the top of the well to the water level. If it is not possible to remove the well cap, remove vent or sanitation access plug.
3. Drop one pellet into the well and listen to hear if it hits the water. If the pellet hits the water, drop one-half the number of pellets determined to be needed into the well. These will sink to the bottom and sanitize the lower part of the well.
4. Mix the remaining pellets in a few gallons of water in a CLEAN plastic container and pour the solution into the well.
5. In order to mix the chlorine thoroughly throughout the entire water system, it is necessary to recirculate the water in the well. This can be accomplished by connection a hose to an out side faucet that is located after the pressure tank. Use hose to run water back down the well (this also rinses upper portion of well). After about 15 minutes of recirculation the water, a strong chlorine odor should be apparent. Turn off hose.
6. Bypass water softener and filters and open each water outlet in the water system until chlorine is present in water. This procedure assures that all the water in the system is chlorinated.
7. Allow the chlorinated water to stand in the system for at least one (1) hour, and preferable overnight. After this, open an outside faucet system until water runs chlorine free. Repeat flush operation on each faucet in system.

NOTE:

A. Chlorine may break loose iron deposits, slime and organic material. This material will make the water run colored. The material broken loose may plug pump screens. **Do not continue to run pump if water doesn't flow.**

B. The high level of chlorine required to sanitize a water system is corrosive to most metals and chlorine solution must **not** be allowed to remain in water system more than 36 hours before being completely flushed from system.

8. After system has been completely flushed, perform a bacteriological analysis on the water following all applicable procedures.

NOTE: Always follow the sanitizing procedure required by applicable state or local laws.

EPA Registered: Well sanitizer pellets are EPA Registered for sanitizing potable water. EPA Registration No. 50510-1

TROUBLESHOOTING GUIDE

PROBLEM	CAUSE	CORRECTION
U.V. lamp will not light	Check input voltage if below or above 120 volts	Install a voltage regulator
	Line cord disconnected or outlet defective	Check, replace
	Defective U.V. lamp	Replace
	Defective lamp ballast	Check output voltage Replace ballast
	Loose open-circuit wire	Trace out and repair
Leak at quartz nipple	Defective or cracked O-Ring	Replace O-Ring
	O-Ring not seated properly	Replace O-Ring

LIMITED WARRANTY

All parts of the disinfection unit, with the exception of the U.V. lamp, are guaranteed for one (1) year against defective parts and workmanship. The stainless steel disinfection chamber on the Triton series is guaranteed for ten (10) years. Any component which fails to operate satisfactorily within their time period will be replaced free of charge under the following conditions:

NOTIFY YOUR LOCAL DEALER OR DISTRIBUTOR OF ANY PARTS SUSPECTED OF BEING DEFECTIVE.

Upon approval by Neptune U.V. Disinfection Systems, the Dealer/Distributor should return the item to Water Treatment & Accessories, LLC 2045 Rockvale Road, Lancaster, PA 17062 (prepaid). If a part proves to be defective, it will be repaired or replaced and returned to the Dealer/Distributor freight paid.

It is the dealer/customer responsibility to reinstall any components which require replacement under warranty. No labor will be covered under this Limited Warranty.

Neptune U.V. Disinfection Systems' or sellers liability is limited to the repair or replacement of any component found to be defective, and in no case shall we be held liable for damage, either immediate or subsequent, arising out of the use of this equipment.

Neptune[®], is the registered trademark of Water Treatment & Accessories, LLC, the manufacturer of Neptune UV brand UV systems, which include the Neptune/"Triton" series. Only parts sold through authorized dealers (or Water Treatment & Accessories, LLC, if there is no dealer in your area), are subject to warranty by Water Treatment & Accessories, LLC. Although lamps and other components purchased from other companies may be "compatible" with the Neptune[®] and Neptune/Triton systems, we cannot warranty any system or parts if non-genuine OEM components are used.

TRITON SPECIFICATIONS

Model #	Max. Flow GPM	No. Lamps	KW @ 120V	AMP @ 120V	Pipe Size	Overall Dimensions L x W x D	Shipping Weight
TRI-8	8	1	0.03	0.25	3/4" MIP	21" x 3.5" x 3.5"	9 Lbs.
TRI-12	12	1	0.03	0.25	3/4" MIP	32" x 3.5" x 3.5"	18 Lbs.
TRI-20	20	1	0.03	0.25	1" MIP	35" x 5" x 5"	21 Lbs.

SUGGESTED PROCEDURE FOR OBTAINING STERILE WATER SAMPLES:

Prior to taking the water sample, be sure to have on hand an adequate supply of sterile bottles. These sterile bottles should be obtained from a reputable laboratory and should have been autoclaved and contained within a plastic outer wrapping.

1. Prior to taking the sample, it is imperative that the sample cock, faucets, etc. be opened at full force for a complete three and one half minutes.
2. After the valve has been left wide open for three and one half minutes, reduce the flow to a reasonable stream of water. Flow to drain an additional three minutes.
3. Open the sterile bottle or sterile container being used. Holding the cap in a down position, the operator should then hold his breath while taking the sample so as to avoid oral contamination of the sample. The operator must not allow his finger to touch the inside of the cap or the neck of the bottle.
4. After the sample has been taken, the cap should immediately be tightly placed on the sample container.
5. The sample container should be placed in a plastic wrapping and should be taken to the laboratory for plating as soon as possible following the above procedure.

We recommend duplicate samples be taken at each test station during each specific test so as to avoid loss of sample through laboratory error and to insure reasonable validity through comparison.

Check with your local laboratory to assure proper sampling and submittal procedure.

WIRING DIAGRAM

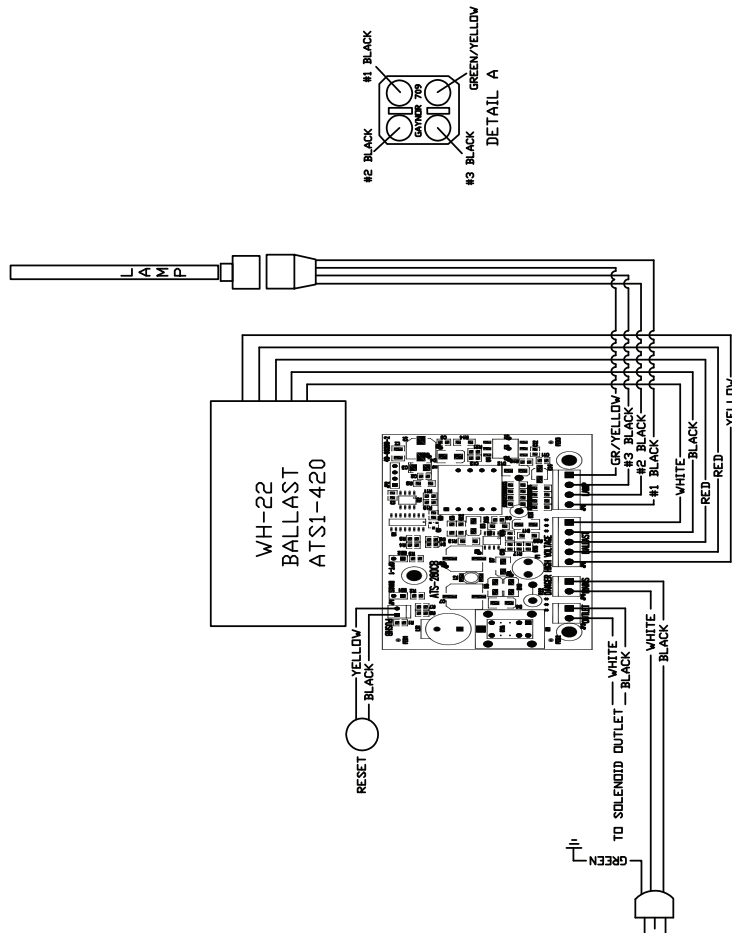

TRI-8

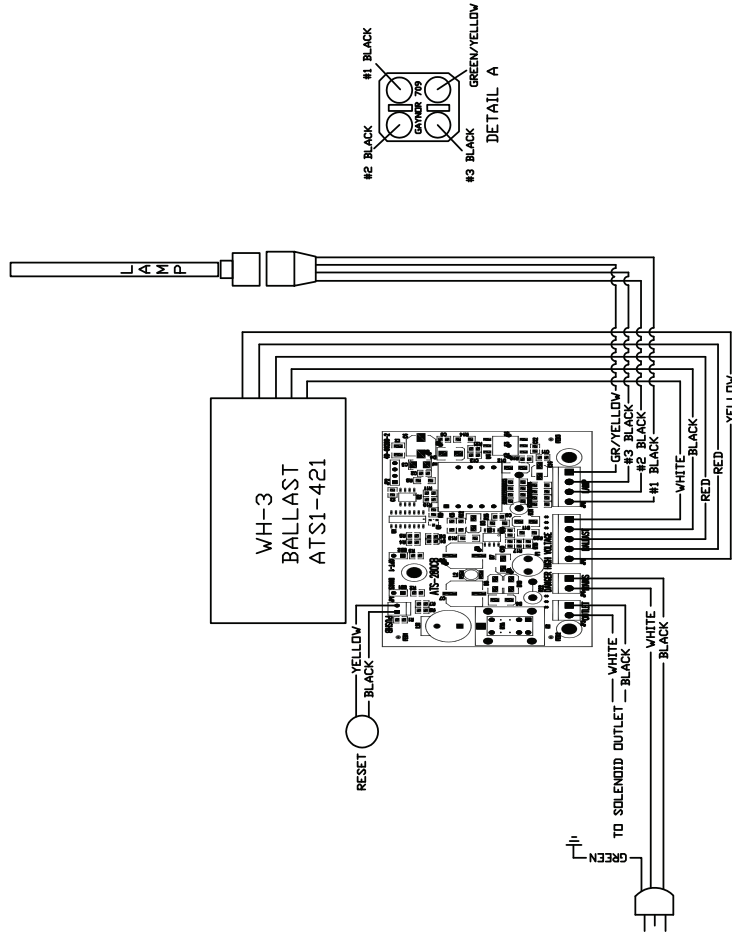



TRI-12, TRI-20

mat'l code	tolerances unless otherwise specified	copy	1
techn no	date	linear	XX +/- .125
		angular	XXX +/- .075
		fit	XXX +/- .050
		dr	LEGARLICK 2/11/88
		proj	
		chr	
		pppt	
Q/graphics folder/Drawings/Shop Drawings/UV Drawings/Wiring Diagram			
WIRING DIAGRAM			
TRI-8, TRI-12, TRI-20			
AQUA TREATMENT SERVICE, INC. 194 HEMPT ROAD MECHANICSBURG, PA 17050 (717) 697-4998 FAX (800) 787-0197			

DRAWING AND PART NUMBERS

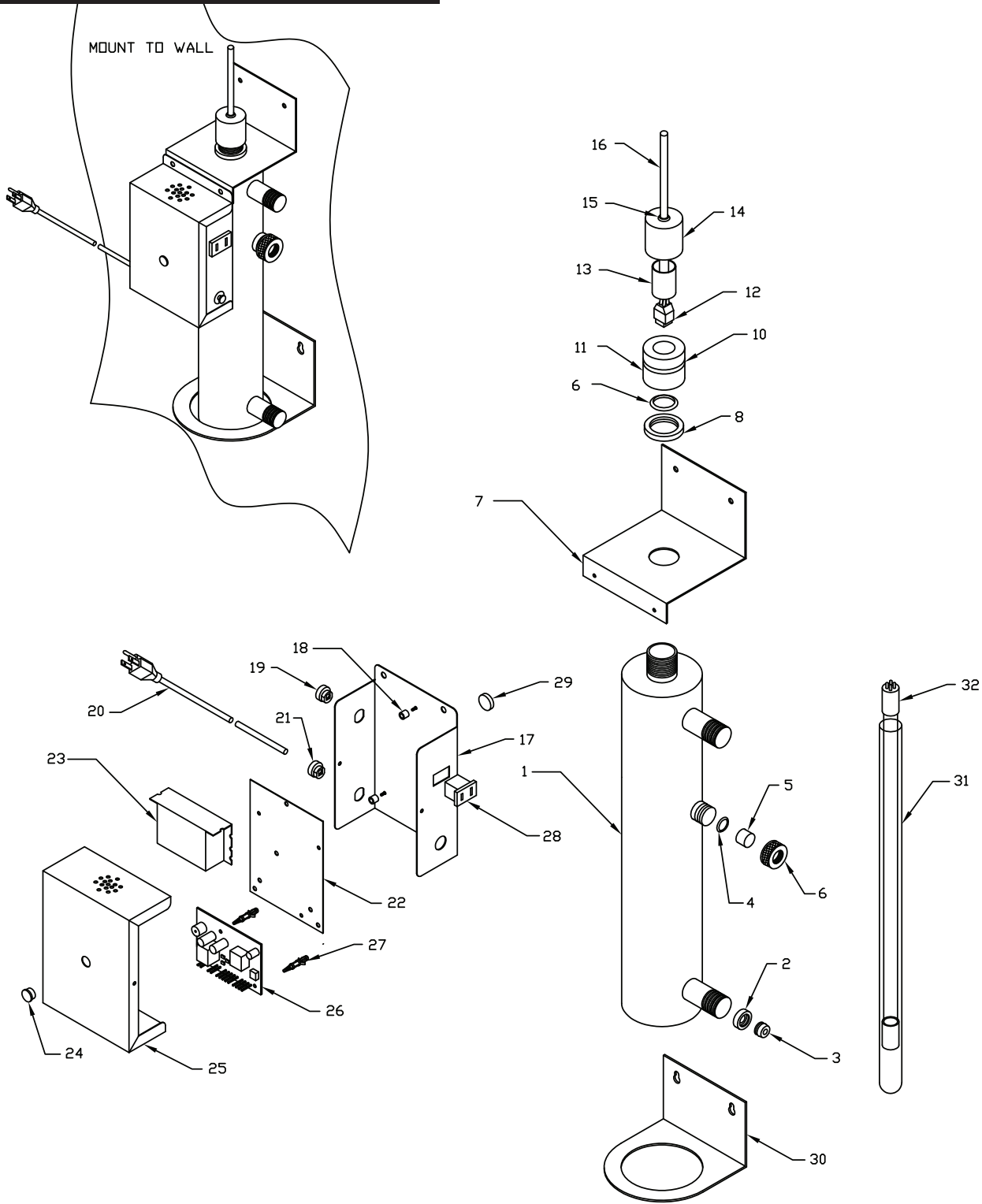
TRI-8 Explosion



mat'l code	tolerances unless otherwise specified		CDPY
tr/ecn no	dr	date	1
	linear	.XX +/- .125	CUSTOMER
		.XXX +/- .075	
		.XXX +/- .050	
	angles	0° +/- 3°	
	dr	T.GARLICK 2/11/08	
	engr		
	chr		
	appd		
 AQUA TREATMENT SERVICE, INC. 194 HEMPT ROAD MECHANICSBURG, PA 17050 (717) 697-4998 FAX (800) 787-0197			
P/N TRI-8			
8 GPM UV W/ MONITOR			

Q:/Graphics folder/Drawings/Shop Drawings/UV Drawings/Bom/Explosions

TRI-8 Parts List

<u>CODE</u>	<u>PART#</u>	<u>DESCRIPTION</u>	<u>QTY.</u>
1	WTA-5249	Chamber	1
2	WTA-R01	¾" Flo.-Et. Retainer 8 gpm	1
3	WTA-F08	8 gpm Flo.-Et.	1
4	WTA-5173	Site Port O-Ring	1
5	WTA-5172	Site Port Lens	1
6	WTA-5171	Site Port Nut	1
7	WTA-268	Top Mounting Bracket	1
8	WTA5-410	Lock Nut	1
9	WTA8-544	End Nut O-Ring (seal quartz sleeve)	1
10	WTA5-409	Brass End Nut	1
11	WTA8-546	O-Ring (for shroud on end nut)	1
12	WTA-7091	Gaynor Connector	1
13	HS4-075-BK	Shrink Tubing	.167
14	WTA-N1155	Brass Shroud	1
15	9600K31	Grommet	1
16	9936K18	Cable	1.5
17	WTA-264	Box Bottom	1
18	WTA-A115	Stand-offs	3
19	WTA-6L3	Strain Relief	1
20	WTA-4000	Power Cord	1
21	WTA-6L1	Strain Relief	1
22	WTA-262	Ballast Plate	1
23	WTA1-420	Ballast 120V/60Hz	1
24	WTA-7600	Plastic Sight Lens (for cover)	1
25	WTA-263	Box Top	1
26	WTA-280CB	Lamp Indicator Circuit Board	1
27	94662A530	Circuit Board Stand-offs	3
28	562-738W-CX2-01	Outlet Plug	1
29	95495K11	Rubber Bumper	1
30	WTA-269	Bottom Mounting Bracket	1
31	WTA-476D	Quartz Sleeve	1
32	WTA4-450	Bulb	1

TRI-12 Explosion

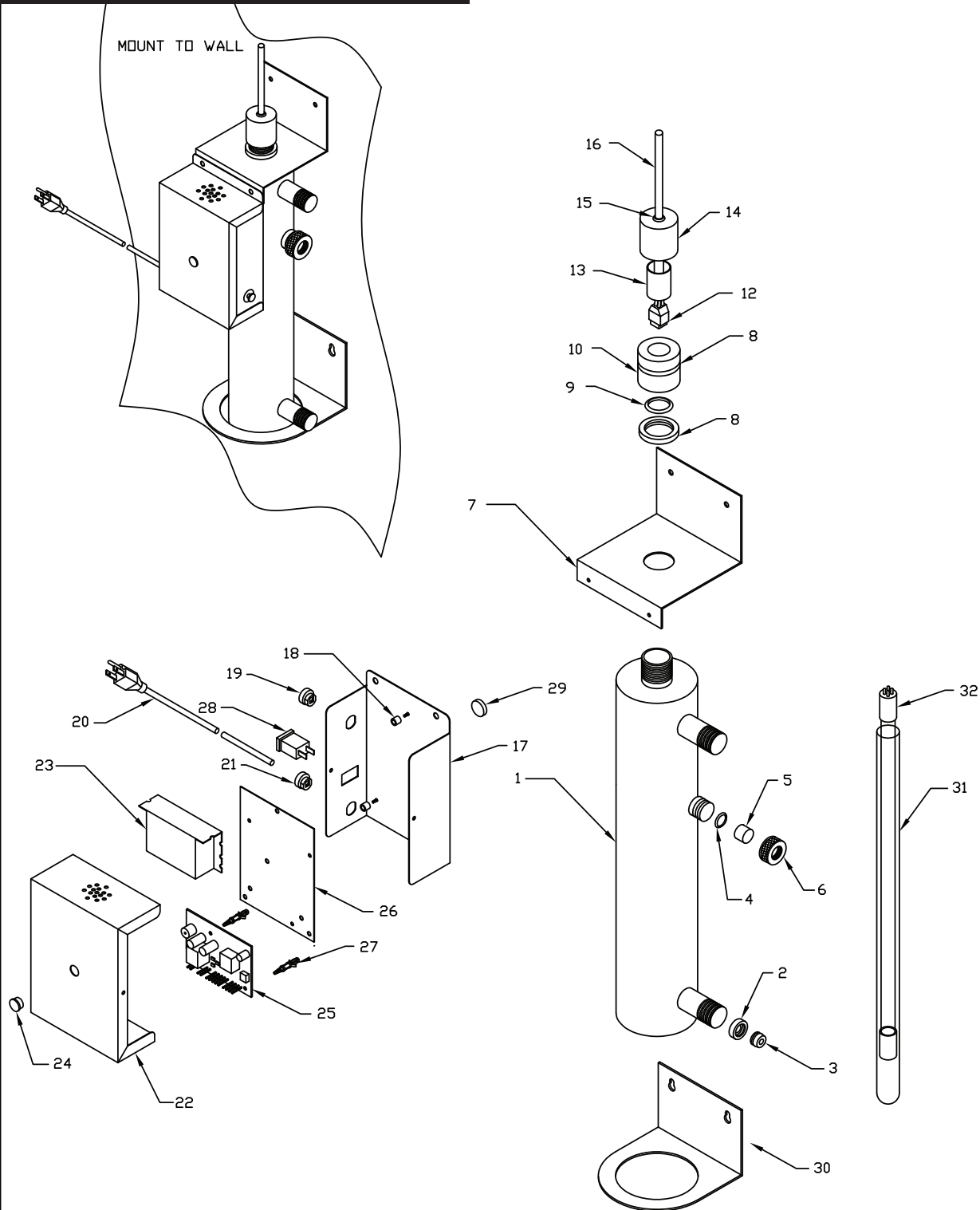

mat'l code	tolerances unless otherwise specified		CDPY
tr/ecn no	dr	date	1
	linear	.XX +/- .125	CUSTOMER
		.XXX +/- .075	
		.XXX +/- .050	
	angles	0° +/- 3°	
	dr	T.GARLICK 2/11/08	
	engr		
	chr		
	appd		
 AQUA TREATMENT SERVICE, INC. 194 HEMPT ROAD MECHANICSBURG, PA 17050 (717) 697-4998 FAX (800) 787-0197			
P/N TRI-12			
12 GPM UV W/ MONITOR			

Q:/Graphics folder/Drawings/Shop Drawings/UV Drawings/Bom/Explosions

TRI-12 Parts List

<u>CODE</u>	<u>PART#</u>	<u>DESCRIPTION</u>	<u>QTY.</u>
1	WTA-5252	Chamber	1
2	WTA-R02	¾" Flo.-Et. Retainer 12 gpm	1
3	WTA-F12	12 gpm Flo.-Et.	1
4	WTA-5173	Site Port O-Ring	1
5	WTA-5172	Site Port Lens	1
6	WTA-5171	Site Port Nut	1
7	WTA-268	Top Mounting Bracket	1
8	WTA5-410	Lock Nut	1
9	WTA8-544	End Nut O-Ring (seal quartz sleeve)	1
10	WTA5-409	Brass End Nut	1
11	WTA8-546	O-Ring (for shroud on end nut)	1
12	WTA-7091	Gaynor Connector	1
13	HS4-075-BK	Shrink Tubing	.167
14	WTA-N1155	Brass Shroud	1
15	9600K31	Grommet	1
16	9936K18	Cable	1.5
17	WTA-267	Box Bottom	1
18	WTA-A115	Stand-offs	3
19	WTA-6L3	Strain Relief	1
20	WTA-4000	Power Cord	1
21	WTA-6L1	Strain Relief	1
22	WTA-265	Ballast Plate	1
23	WTA1-421	Ballast 120V/60Hz	1
24	WTA-7600	Plastic Sight Lens (for cover)	1
25	WTA-266	Box Top	1
26	WTA-280CB	Lamp Indicator Circuit Board	1
27	94662A530	Circuit Board Stand-offs	3
28	562-738W-CX2-01	Outlet Plug	1
29	95495K11	Rubber Bumper	1
30	WTA-269	Bottom Mounting Bracket	1
31	WTA-759D	Quartz Sleeve	1
32	WTA4-739	Bulb	1

TRI-20 Explosion

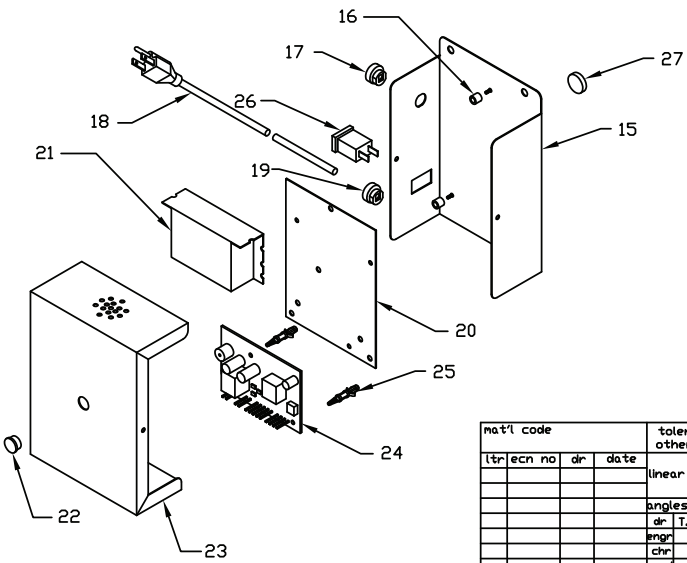
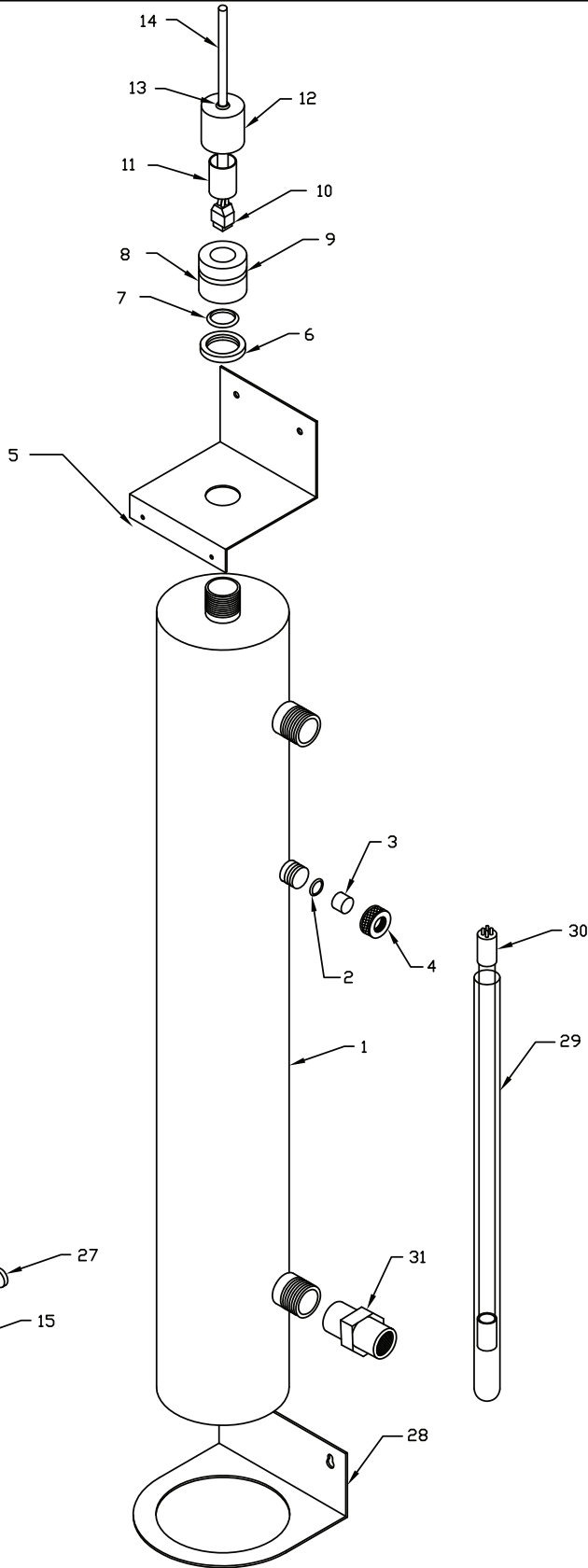
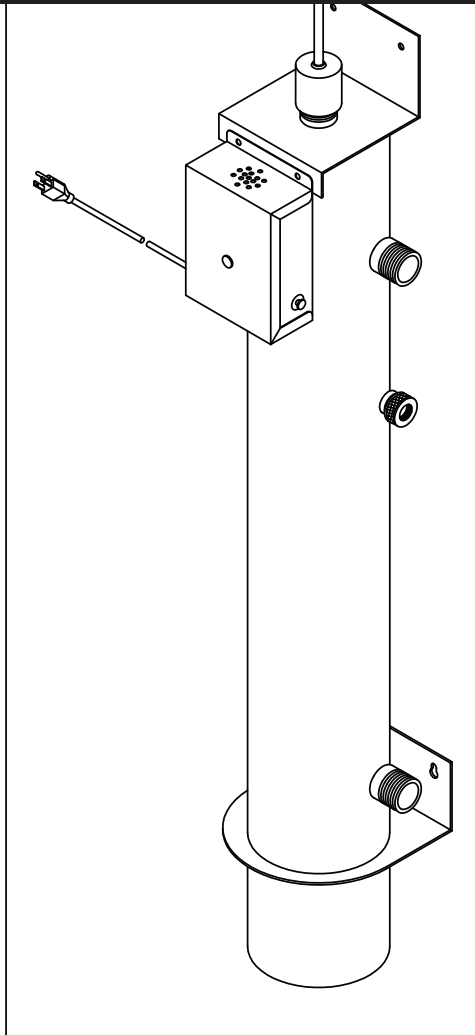

mat'l code	tolerances unless otherwise specified	CDPY 1	 AQUA TREATMENT SERVICE, INC. 194 HEMPT ROAD MECHANICSBURG, PA 17050 (717) 697-4998 FAX (800) 787-0197
tr/ecn no	dr date	CUSTOMER	
	linear .XX +/- .125		P/N TRI-20
	.XXX +/- .075		20 GPM UV W/ MONITOR
	.XXX +/- .050		
	angles 0° +/- .3°		
	dr T.GARLICK 2/11/08		
	engr		
	chr		
	appd		

Q:/Graphics folder/Drawings/Shop Drawings/UV Drawings/Bom/Explosings

TRI-20 Parts List

<u>CODE</u>	<u>PART#</u>	<u>DESCRIPTION</u>	<u>QTY.</u>
1	WTA-5266	Chamber	1
2	WTA-5173	Site Port O-Ring	1
3	WTA-5172	Site Port Lens	1
4	WTA-5171	Site Port Nut	1
5	WTA-270	Top Mounting Bracket	1
6	WTA5-410	Lock Nut	1
7	WTA8-544	End Nut O-Ring (seal quartz sleeve)	1
8	WTA5-409	Brass End Nut	1
9	WTA8-546	O-Ring (for shroud on end nut)	1
10	WTA-7091	Gaynor Connector	1
11	HS4-075-BK	Shrink Tubing	.167
12	WTA-N1155	Brass Shroud	1
13	9600K31	Grommet	1
14	9936K18	Cable	1.5
15	WTA-267	Box Bottom	1
16	WTA-A115	Stand-offs	3
17	WTA-6L3	Strain Relief	1
18	WTA-4000	Power Cord	1
19	WTA-6L1	Strain Relief	1
20	WTA-265	Ballast Plate	1
21	WTA1-421	Ballast 120V/60Hz	1
22	WTA-7600	Plastic Sight Lens (for cover)	1
23	WTA-266	Box Top	1
24	WTA-280CB	Lamp Indicator Circuit Board	1
25	94662A530	Circuit Board Stand-offs	3
26	562-738W-CX2-01	Outlet Plug	1
27	95495K11	Rubber Bumper	1
28	WTA-271	Bottom Mounting Bracket	1
29	WTA-832D	Quartz Sleeve	1
30	WTA4-810	Bulb	1
31	V7A106D-20	20 gpm Flow Control	1