

Model 6600 Downflow

Service Manual



IMPORTANT: Fill in pertinent information on *page 3* for future reference.

Model 6600 Downflow

Table of Contents

<i>Job Specification Sheet</i>	3
<i>General Residential Installation Check List</i>	4
<i>Valve Installation and Start-up Procedures</i>	5
<i>Control Start-up Procedures</i>	6
<i>Display</i>	6
<i>Set Time of Day</i>	6
<i>Start an Extra Regeneration Cycle</i>	7
<i>Set Control Programming</i>	7
<i>*Fast Cycle Regeneration</i>	8
<i>Final Setup</i>	9
<i>Control Operation</i>	10
<i>Immediate Regeneration Valves with Days Between Regeneration Override Set</i>	10
<i>Delayed Regeneration Valves with Days Between Regeneration Override Set</i>	10
<i>Control Operation During Regeneration</i>	10
<i>Control Operation During Programming</i>	10
<i>Control Operation During A Power Failure</i>	10
<i>Water Conditioner Flow Diagrams (Downflow Brining)</i>	11
<i>Service Position</i>	11
<i>Backwash Position</i>	12
<i>Brine/Slow Rinse Position</i>	12
<i>Second Backwash Position (Double Backwash Units Only)</i>	13
<i>Rapid Rinse Position</i>	12
<i>Brine Tank Fill Position</i>	13
<i>Service Position</i>	13
<i>Control Valve Assembly</i>	16
<i>Valve Powerhead Assembly</i>	18
<i>Meter Assembly</i>	20
<i>Bypass Valve Assembly, Plastic</i>	21
<i>Bypass Valve Assembly, Brass</i>	22
2300 <i>Safety Brine Valve</i>	23
2310 <i>Safety Brine Valve</i>	24
<i>Valve Wiring Diagram</i>	26
<i>Service Instructions</i>	27
<i>Brine Valve, Injectors and Screen Replacement</i>	27
<i>Brine Valve Replacement</i>	27
<i>Injectors/Screen Replacement</i>	27
<i>Timer Replacement</i>	28
<i>Piston Assembly Replacement</i>	28
<i>Seal and Spacer Replacement</i>	29
<i>Meter Replacement</i>	29
<i>Meter Cover/Impeller Replacement</i>	30
<i>Troubleshooting</i>	31
<i>Service Assemblies</i>	33

Model 6600 Downflow

Job Specification Sheet

Job Number _____

Model Number _____

Water Test _____

Capacity Of Unit _____ Max. _____ Per Regeneration

Mineral Tank Size: Diameter _____ Height _____

Under Bedding _____ Amount _____

Type Of Media _____ Cubic Feet _____

Brine Tank Size _____

Salt Setting Per Regeneration _____

Valve Programming

Treated Water Capacity _____ (Gallons / Liters)

Regeneration Day Override _____ (Max. Days Between Regen.)

Regeneration Time _____ (A.M.) (P.M.)

Model 6600 Downflow

General Residential Installation Check List

Water Pressure

A minimum of 25 lbs of water pressure is required for regeneration valve to operate effectively.

Electrical Facilities

An uninterrupted alternating current (A/C) supply is required. Please make sure voltage supply is compatible with unit before installation.

Existing Plumbing

Condition of existing plumbing should be free from lime and iron buildup. Replace piping that has heavy lime and/or iron build-up. If piping is clogged with iron, install a separate iron filter unit ahead of the water softener.

Location of Softener and Drain

Locate the softener close to a clean working drain and connect according to local plumbing codes.

Bypass Valves

Always provide for the installation of a bypass valve if unit is not equipped with one.

	<p>CAUTION</p> <ul style="list-style-type: none">• Do not exceed 120 psi water pressure.• Do not exceed 110°F water temperature.• Do not subject unit to freezing conditions.
---	---

Model 6600 Downflow

Valve Installation and Start-up Procedures

1. Place the softener tank where you want to install the unit.
NOTE: Be sure the tank is level and on a firm base.
2. During cold weather it is recommended that the installer warm the valve to room temperature before operating.
3. Perform all plumbing according to local plumbing codes.
 - Use a 1/2" minimum pipe size for the drain.
 - Use a 3/4" drain line for backwash flow rates that exceed 7 gpm or length that exceeds 20' (6 m).
4. Cut the 1" distributor tube (1.050 O.D.) flush with top of each tank.
5. Lubricate the distributor o-ring seal and tank o-ring seal. Place the main control valve on tank.
NOTE: Only use silicone lubricant.
6. Solder joints near the drain must be done before connecting the Drain Line Flow Control fitting (DLFC). Leave at least 6" (152 mm) between the DLFC and solder joints when soldering pipes that are connected on the DLFC. Failure to do this could cause interior damage to DLFC.
7. Use only *Teflon* tape on the drain fitting.
8. Be sure the floor under the salt storage tank is clean and level.
9. Place approximately 1" (25 mm) of water above the grid plate. If a grid is not utilized, fill to the top of the air check in the salt tank. Do not add salt to the brine tank at this time.
10. On units with a bypass, place in **Bypass** position.
 - Turn on the main water supply.
 - Open a cold soft water tap nearby and let water run a few minutes or until the system is free of foreign material (usually solder) resulting from the installation. Close the water tap when water runs clean.
11. Place the bypass in the Service position and let water flow into the mineral tank. When water flow stops, slowly open a cold water tap nearby and let water run until air is purged from the unit. Then close tap.
12. Plug the valve into an approved power source. When the valve has power it drives to the **In Service** position.

Model 6600 Downflow

Control Start-up Procedures

Display

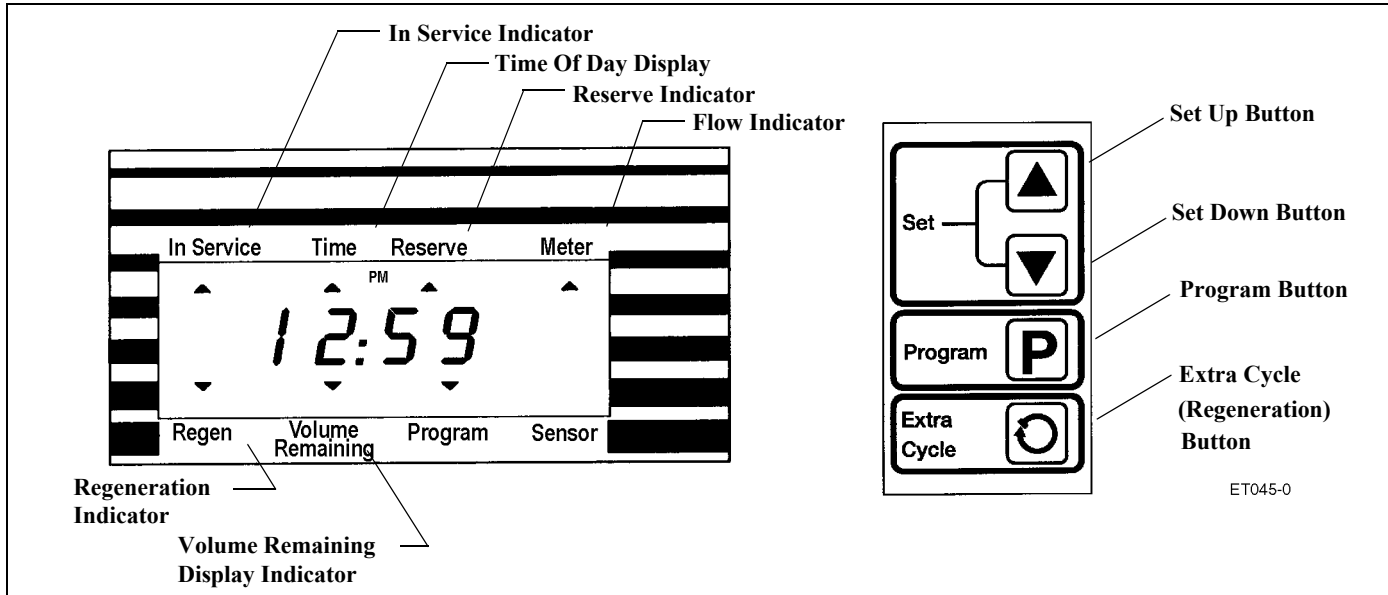

Figure 1: 6600 Display

In normal operation the **Time Of Day** display alternates with the **Volume Remaining** display. As treated water is used, the **Volume Remaining** display counts down (in gallons) from a maximum value to zero or (----). Once this occurs a regeneration cycle initiates immediately or delayed to the set **Regeneration Time**. Water flow through the valve is indicated by the flashing **Flow Indicator**.

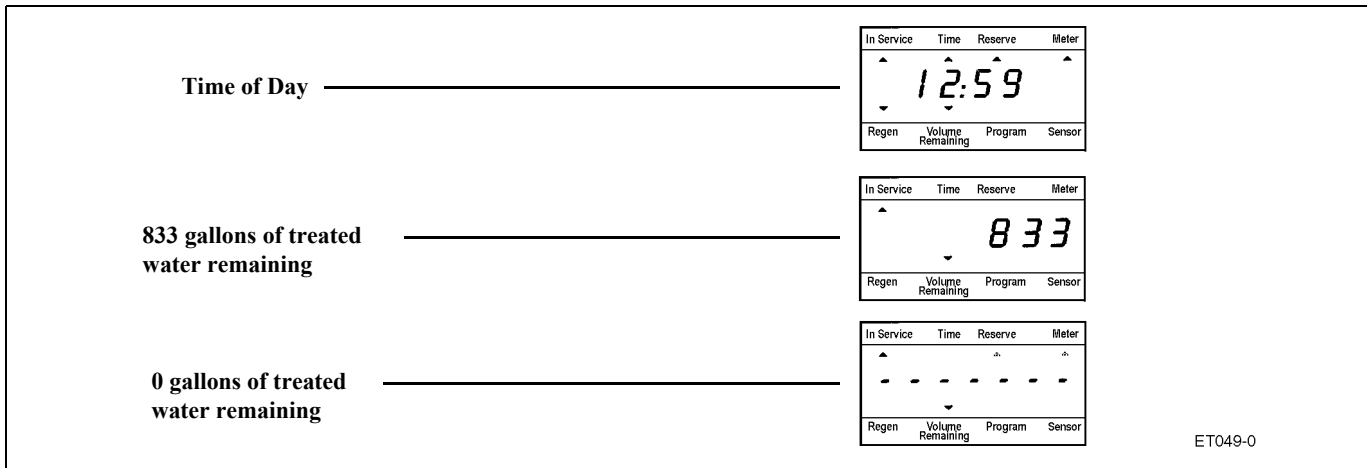

Figure 2: Time of Day and Volume Remaining

Model 6600 Downflow

Control Start-Up Procedures (Cont'd.)

Set Time of Day

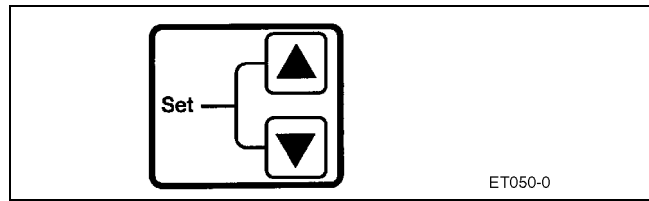
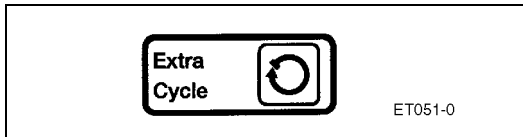

Figure 3: Set Up and Set Down Buttons

When the valve is **In Service**, push either the **Set Up** or **Set Down** button once to adjust the **Time Of Day** by one digit. Push and hold to adjust by several digits.

Start an Extra Regeneration Cycle



Push the **Extra Cycle** button to start an extra regeneration tonight. Push and hold the **Extra Cycle** button for 5 seconds (for delayed regeneration only) to start a regeneration immediately.

Set Control Programming

1. Push and hold both the **Program** button for 5 seconds. The Program arrow will illuminate when in the programming mode.



2. Set the Water Hardness. Using the **Set Up** or **Set Down** buttons, set the Grains Per Gallon value.

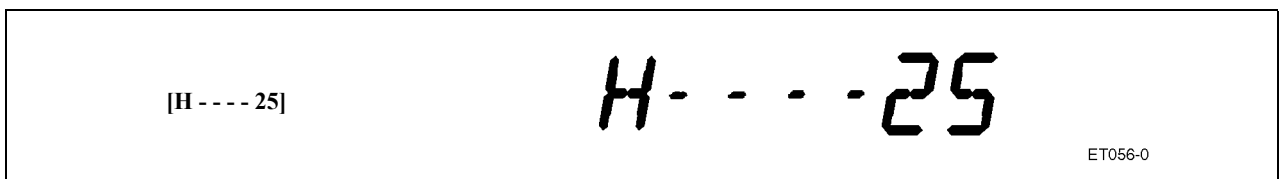

Figure 4: Set Water Hardness

3. Push the **Program** button to accept the above value and move to the next setting.



Model 6600 Downflow

Control Start-Up Procedures (Cont'd.)

- Set the **Water Hardness After Mixing Valve**. Use the **Set Up** or **Set Down** buttons to set the desired value.

NOTE: The **Water Hardness After Mixing Valve** display can only be viewed in Metric display formats [U2] and [U4].

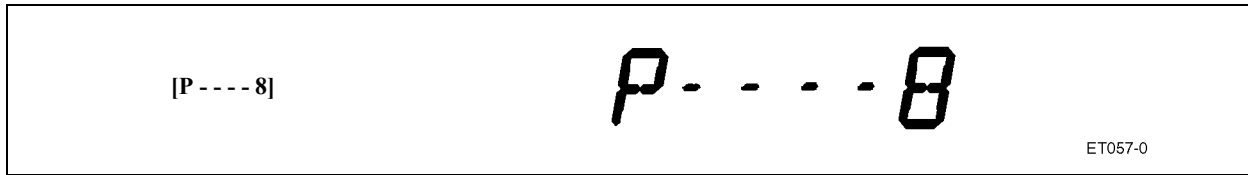

Figure 5: Set Water Hardness After Mixing Valve

- Push the **Program** button to accept the above value and move to the next setting.



- Set **Regeneration Time**. Use the **Set Up** or **Set Down** buttons to set the time a regeneration cycle will occur.

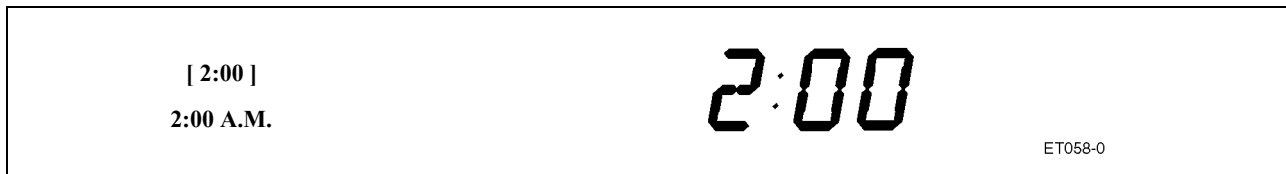

Figure 6: Set Regeneration Time

- Push the **Program** button to accept the above value and exit the programming mode. The Program arrow will no longer be illuminated when the programming mode has been exited.



Fast Cycle Regeneration

Perform the following Fast Cycle Regeneration if setting up the system for the first time:

- Push the **Extra Cycle** button for 5 seconds to force an extra regeneration immediately.
- Once the valve reaches Regeneration Cycle, step 1, let water run to drain for approximately 5 minutes.
- Push the **Extra Cycle** button once to advance valve to Regeneration Cycle, step 2.
- Push the **Extra Cycle** button once to advance valve to Regeneration Cycle, step 3.
- Push the **Extra Cycle** button once to advance valve to Regeneration Cycle, step 4.
- Push the **Extra Cycle** button once more to advance the valve back to **In Service**.

Model 6600 Downflow

Control Start-Up Procedures (Cont'd.)

Final Setup

With proper valve operation verified:

1. Add water to the top of the air check. Manually step the valve to the **Brine Draw** position and allow the valve to draw water from the brine tank until it stops.
NOTE: The air check will check at approximately the midpoint of the screened intake area.
2. Manually step the valve to the **Brine Refill** position and allow the valve to return to the **In Service** position automatically.
3. With the valve in the Service position, check that there is approximately 1" (25 mm) of water above the grid in the brine tank, if used.
4. Fill the brine tank with salt.
5. Setup is complete, the control can now run automatically.

NOTE: A 9V alkaline battery is recommended to be installed on the battery back-up harness for proper valve operation.

Model 6600 Downflow

Control Operation

Immediate Regeneration Valves with Days Between Regeneration Override Set

When the valve reaches its set **Days Since Regeneration Override** value, a regeneration cycle initiates immediately. This event occurs regardless of the **Volume Remaining** display having reached zero gallons.

Delayed Regeneration Valves With Days Between Regeneration Override Set

When the valve reaches its set **Days Since Regeneration Override** value a regeneration cycle initiates at the preset **Regeneration Time**. This event occurs regardless of the **Volume Remaining** display having reached zero gallons.

Control Operation During Regeneration

In **Regeneration** the control displays a special **Regeneration** display. In this display the control shows the current regeneration step number the valve is advancing to, or has reached, and the time remaining in that step. The step number flashes until the valve completes driving to this regeneration step position. Once all regeneration steps are complete the valve returns to **In Service** and resumes normal operation.

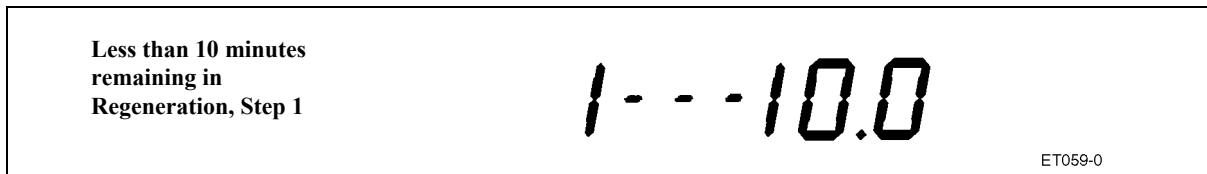

Figure 7: Regeneration Display

Pushing the **Extra Cycle** button during a **Regeneration** cycle immediately advances the valve to the next cycle step position and resumes normal step timing.

Control Operation During Programming

The control only enters the **Program Mode** with the valve **In Service**. While in the **Program Mode** the control continues to operate normally monitoring water usage and keeps all displays up to date. Control programming is stored in memory permanently. There is no need for battery backup power.

Control Operation During A Power Failure

During a power failure all control displays are kept up to date using battery backup power. Once backup power fails, these displays and valve programming are stored for use upon power re-application. The control retains these values for years, if necessary, without loss. The control is fully inoperative and any calls for regeneration are delayed. The control, upon power re-application, resume normal operation from the point that it was interrupted. An indication that a power outage has occurred is an inaccurate or flashing **Time Of Day** display.

Model 6600 Downflow

Water Conditioner Flow Diagrams (Downflow Brining)

Single Backwash Positions Black Cycle Cam (Part Number 17438)	Double Backwash Positions Blue Cycle Cam (Part Number 40609)
Service Position 1. Backwash Position 2. Brine/Slow Rinse Position 3. Rapid Rinse Position 4. Brine Tank Fill Position Service Position	Service Position 1. First Backwash Position 2. Brine/Slow Rinse Position 3. Second Backwash Position 4. Rapid Rinse Position 5. Brine Tank Fill Position Service Position

Service Position

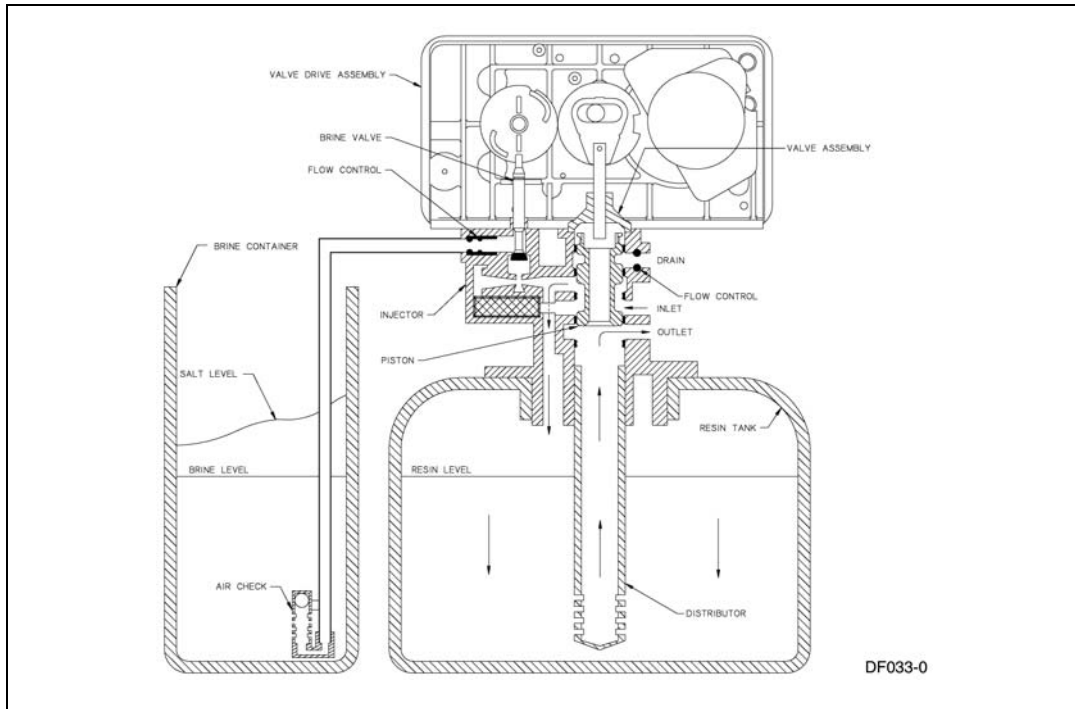

Figure 8: Service Position

Model 6600 Downflow

Water Conditioner Flow Diagrams (Downflow Brining)

Backwash Position

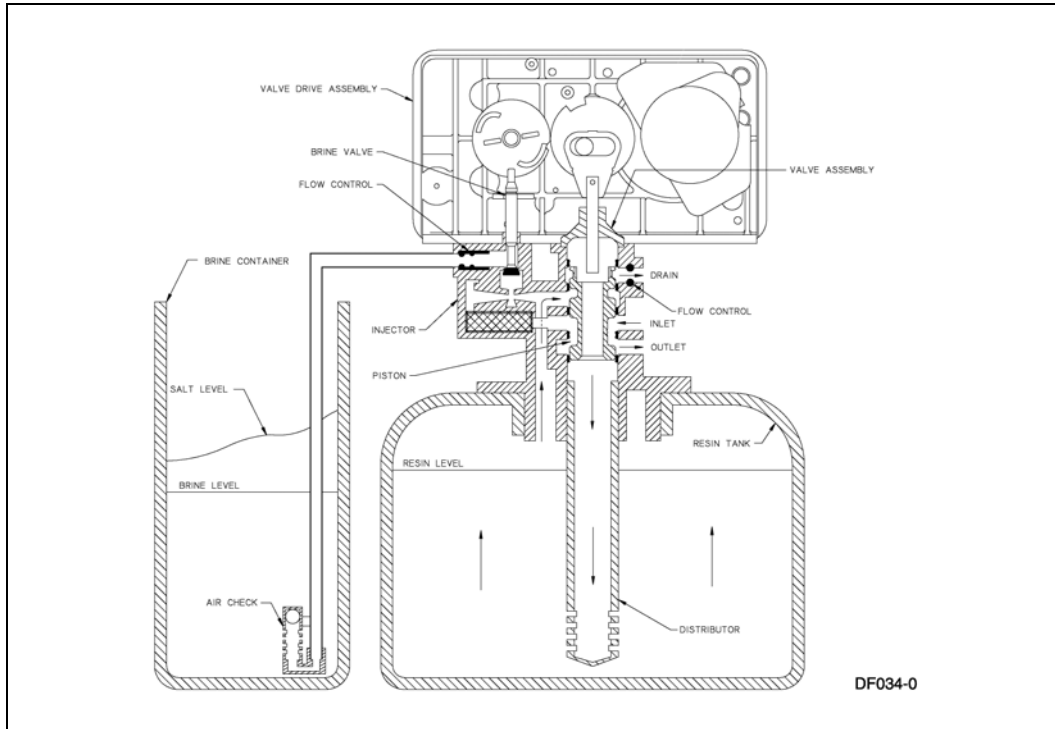

Figure 9: Backwash Position

Brine/Slow Rinse Position

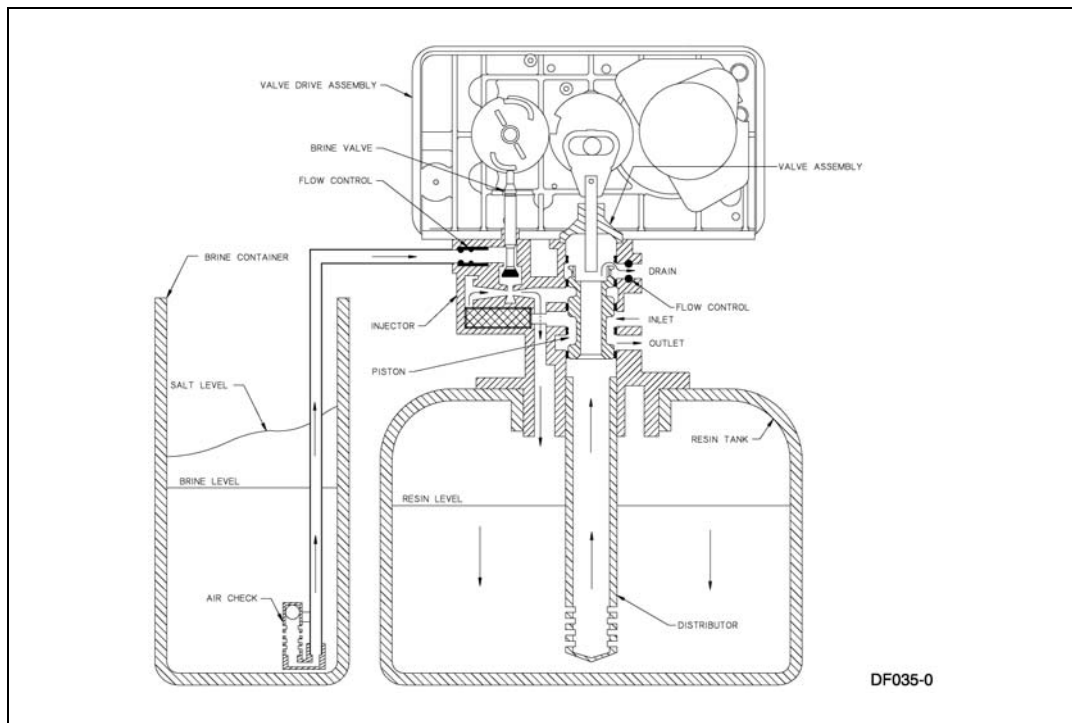

Figure 10: Brine/Slow Rinse Position

Model 6600 Downflow

Water Conditioner Flow Diagrams (Downflow Brining)

Second Backwash Position (Double Backwash Units Only)

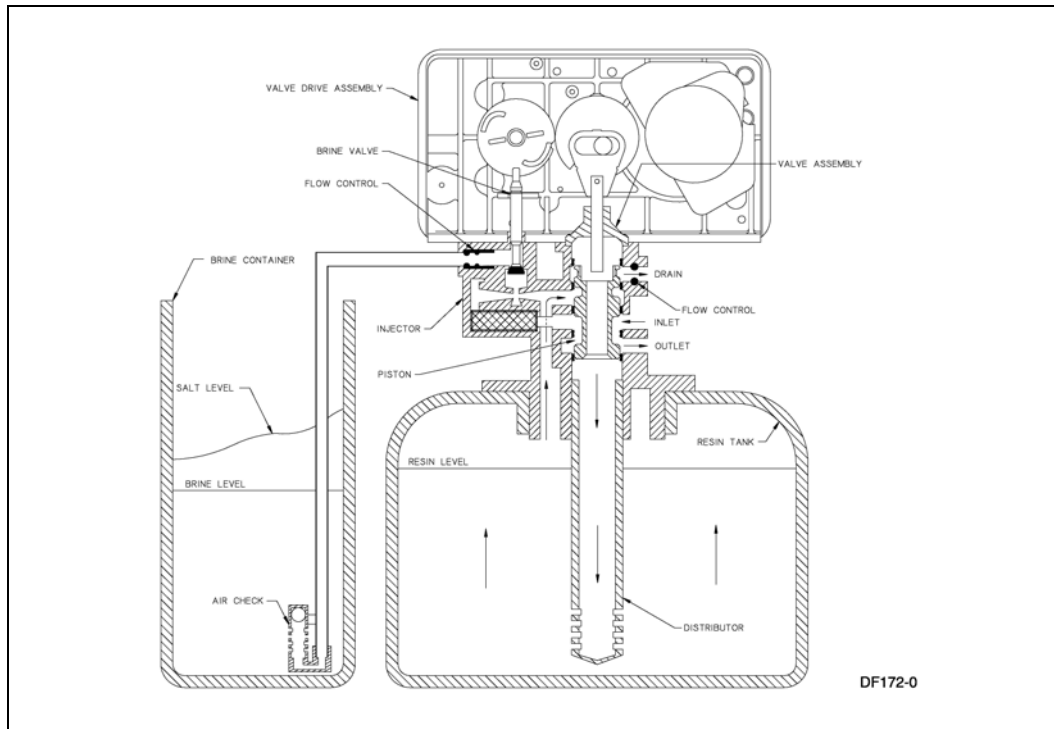

Figure 11: Second Backwash Position (Double Backwash Units Only)

Rapid Rinse Position

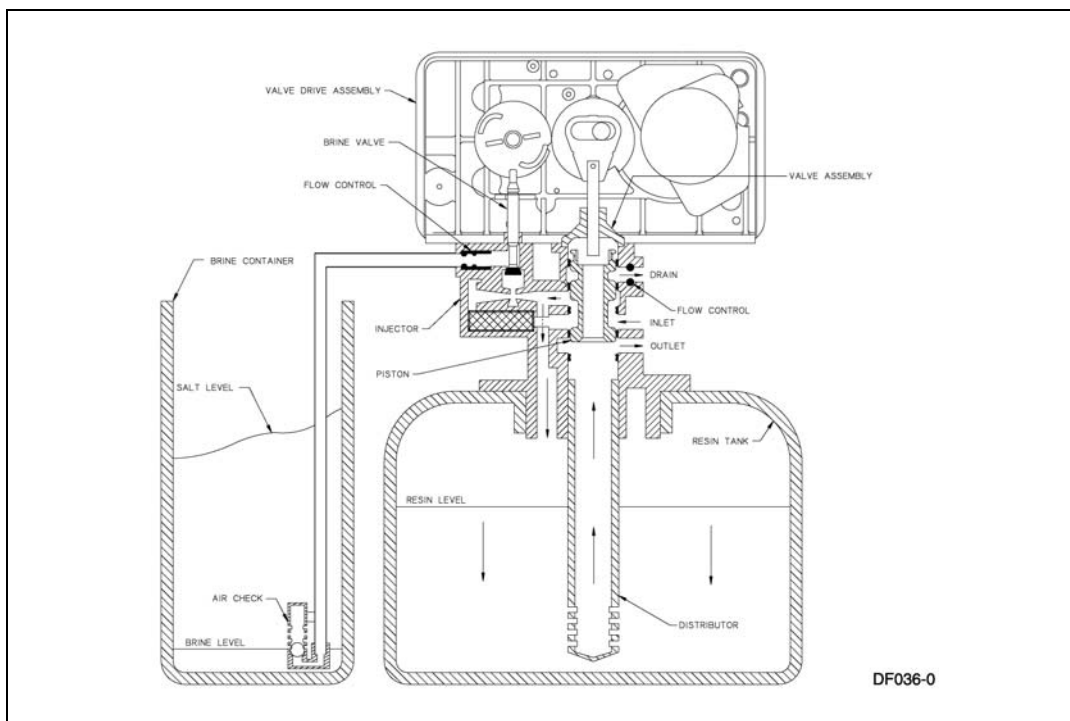

Figure 12: Rapid Rinse Position

Model 6600 Downflow

Water Conditioner Flow Diagrams (Downflow Brining)

Brine Tank Fill Position

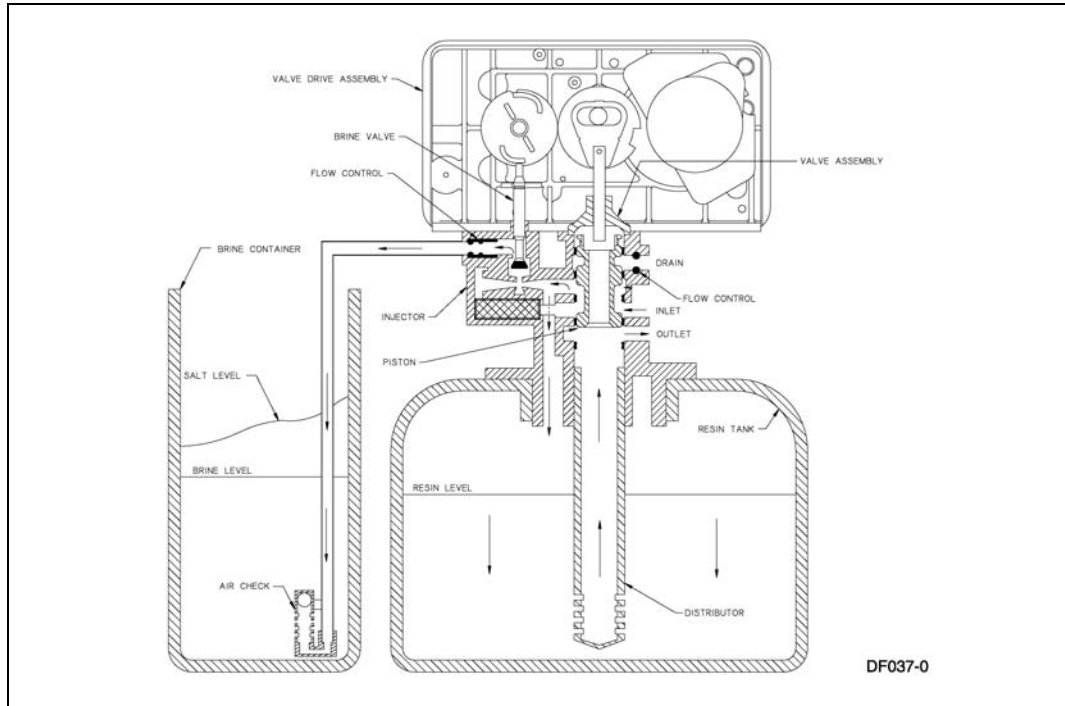

Figure 13: Brine Tank Fill Position

Service Position

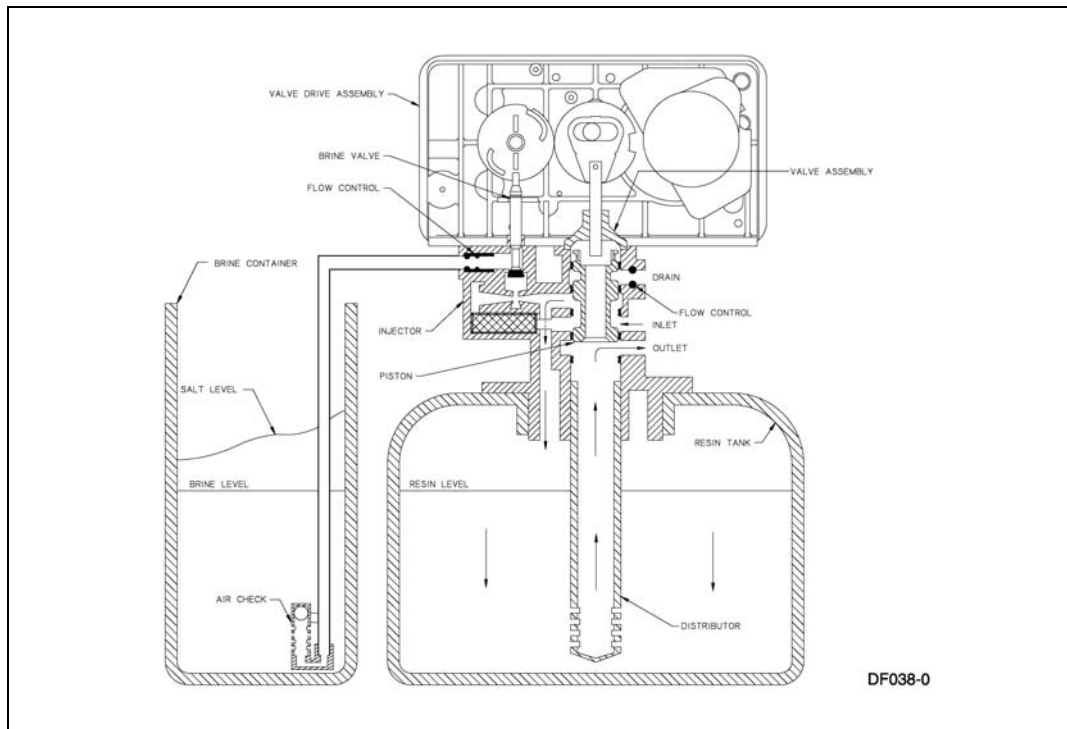

Figure 14: Service Position

Model 6600 Downflow

Notes

Model 6600 Downflow

Control Valve Assembly

* Not used in metered controls

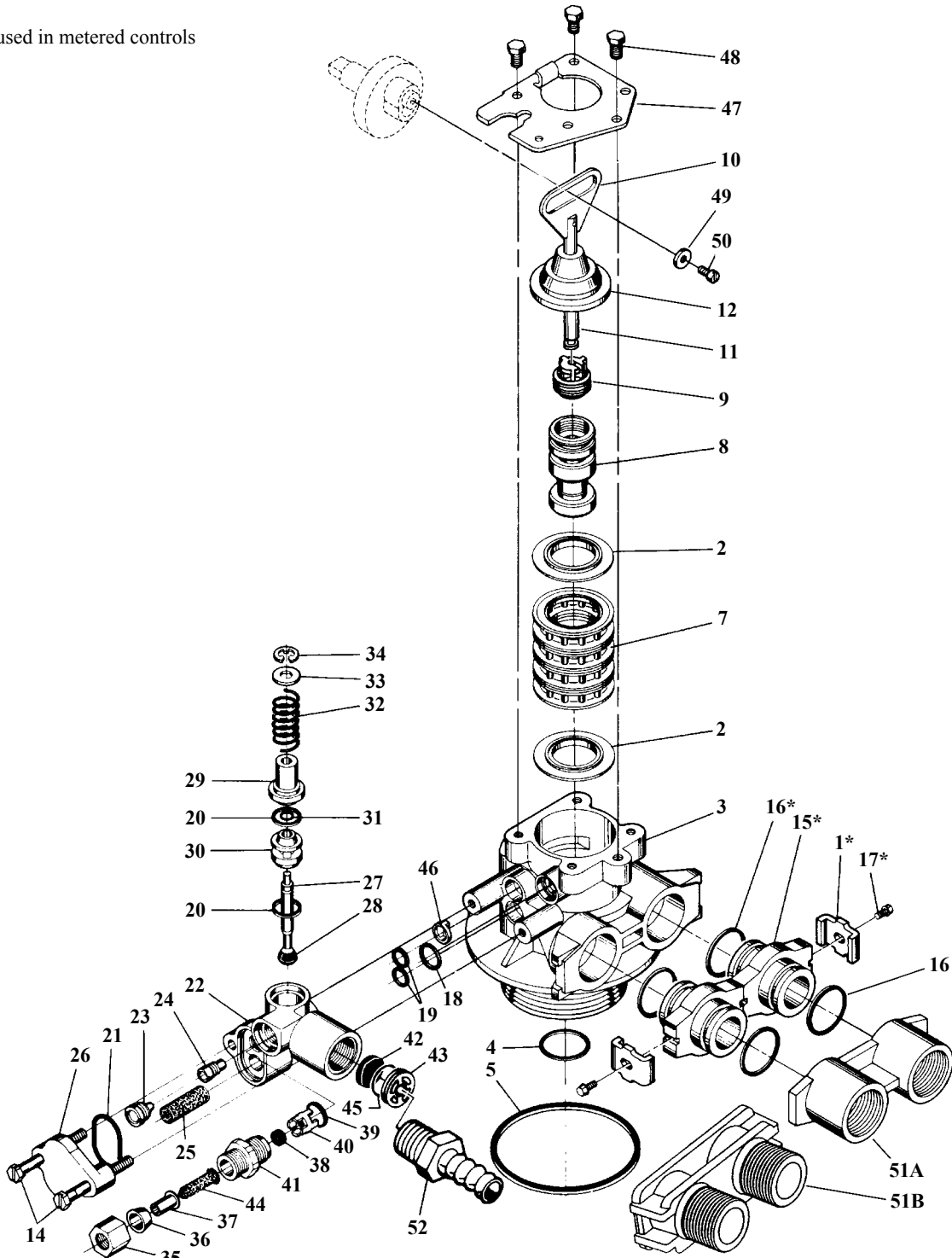

DF039-0

Figure 15: Control Valve Assembly

Model 6600 Downflow

Control Valve Assembly (Cont'd.)

<i>Item Number</i>	<i>No. Req'd</i>	<i>Part Number</i>	<i>Description</i>
1	2	13255	adapter clip (not used in metered controls)
2	5	13242	seal
3	1	14449	valve body assembly, 1" dist.
	1	14450	valve body assembly, 13/16" dist.
4	1	13304	o-ring, distributor tube, 1"
	1	10244	o-ring, distributor tube, 13/16"
5	1	12281	o-ring, top of tank
7	4	14241	spacer
8	1	17218	piston (used with black cycle cam)
9	2	14309	piston rod retainer
	2	16590	piston rod retainer, HW (hot water)
10	1	13001-04	piston rod assembly
11	1	14919	piston rod
12	1	13446-40	end plug assembly, green
14	2	13315	screw, injector mounting
15	2	19228	adapter coupling
16	4	13305	o-ring, adapter coupling
17	2	13314	screw, adapter coupling
18	1	12638	o-ring, drain
19	2	13301	o-ring, injector
20	2	13302	o-ring, brine spacer
21	1	13303	o-ring, injector cover
22	1	13163	injector body
23	1	10913	injector nozzle, specify size
24	1	10914	injector throat, specify size
25	1	10227	injector screen
26	1	13166	injector cover
27	1	13172	brine valve stem
28	1	12626	brine valve seat
29	1	13165	brine valve cap
30	1	13167	brine valve spacer
31	1	12550	quad ring
32	1	11973	spring, brine valve
33	1	16098	washer, brine valve
34	1	11981-01	retaining ring
35	1	10329	BLFC fitting nut, 3/8"
36	1	10330	BLFC ferrule, 3/8"
37	1	10332	BLFC tube insert, 3/8"
38	1		BLFC button, specify size
39	1	12977	o-ring, BLFC
40	1	13245	BLFC button retainer
41	1	13244	BLFC fitting
42	1		DLFC button, specify size
43	1	13173	DLFC button retainer
44	1	12767	screen, brine line
45	1	15348	o-ring, DLFC
46	1	13497	air disperser
47	1	13546	end plug retainer
48	3	12112	screw
49	1	13363	washer
50	1	13296	screw
51A	1	13398	yoke, brass, 1" NPT
	1	13708	yoke, brass, 3/4" NPT
51B	1	18706	yoke, plastic, 1" NPT
	1	18706-02	yoke, plastic, 3/4" NPT
52	1	13308	drain hose barb

Model 6600 Downflow

Valve Powerhead Assembly

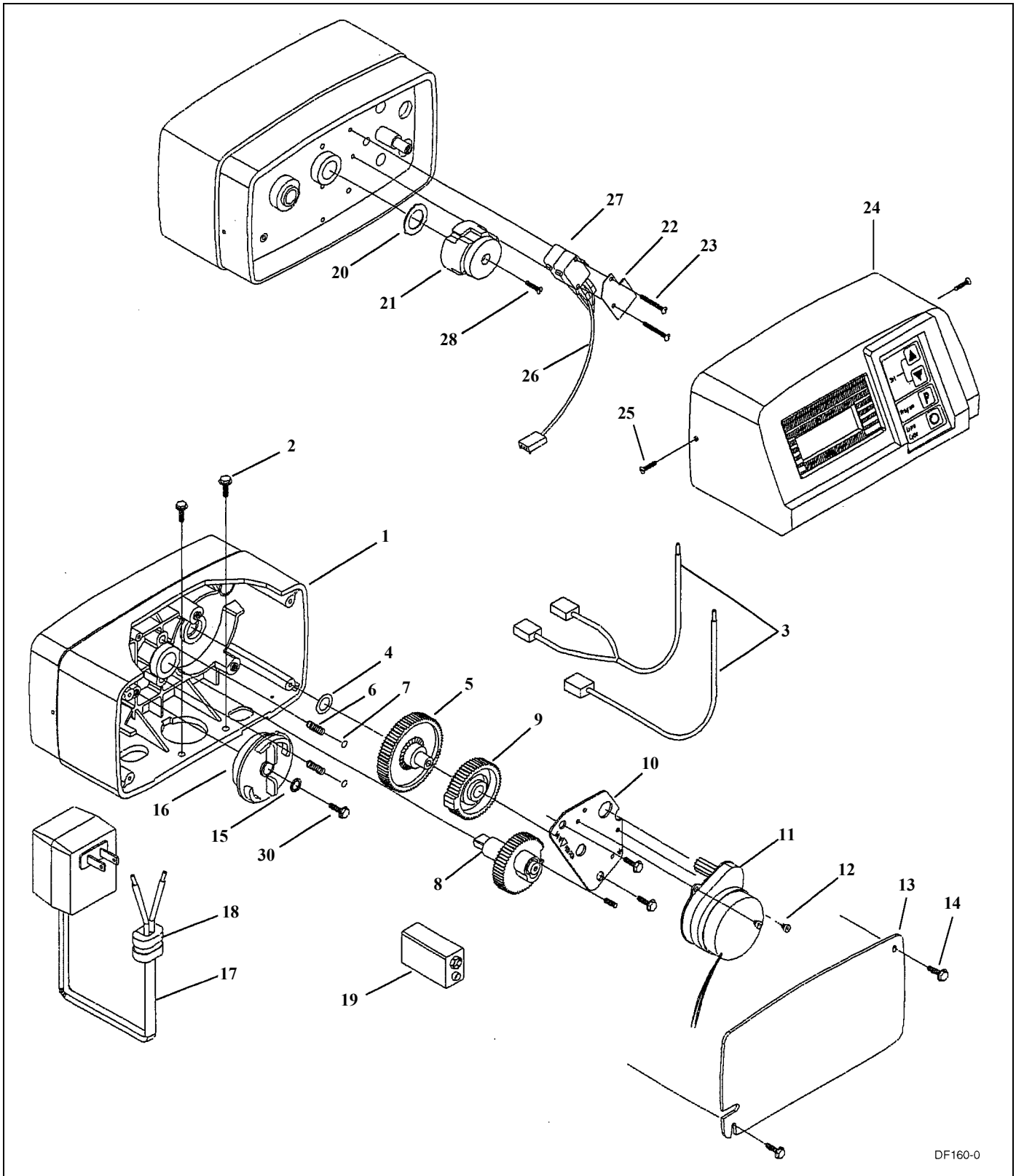

Figure 16: Valve Powerhead Assembly

Model 6600 Downflow

Valve Powerhead Assembly (Cont'd.)

<i>Item Number</i>	<i>No. Req'd</i>	<i>Part Number</i>	<i>Description</i>
1	1	26001-02	drive housing, black
2	2	12473	screw, drive mount
3	1	40042-01	wire harness, power
4	1	13299	spring washer
5	1	13017	idler gear
6	2	19080	spring, detent
7	2	13300	ball, detent
8	1	25005	main drive gear and shaft (downflow brining, black)
9	1	23045	drive gear
10	1	13175	motor mounting plate
11	1	16944	drive motor, 2RPM 24V 50/60 Hz
12	3	11384	screw, motor
13	1	13229	back plate
14	4	13296	screw, component
15	1	12037	washer
16	1	18722	cam, brine valve
17	1	19674	transformer, 24V 9.6VA (US 120V)
	1	25651	transformer, 24V 9.6VA (European 230V)
18	1	13547	strain relief
19	1		9V alkaline battery (not included)
20	1	19079	washer, friction
21	1	17438	cycle cam (downflow brining, black, single backwash)
	1	40609	cycle cam (downflow brining, blue, double backwash)
22	1	10302	insulator
23	2	17876	screw, microswitch
24	1	60751-xx	front panel assembly (specify color/voltage)
25	2	13898	screw, front panel
26	1	40041-01	wire harness, low voltage
27	2	10218	microswitch
28	1	15151	screw, cycle cam
29	4	12681	wire nut, beige (not shown)
30	1	40214	screw

Model 6600 Downflow

Meter Assembly

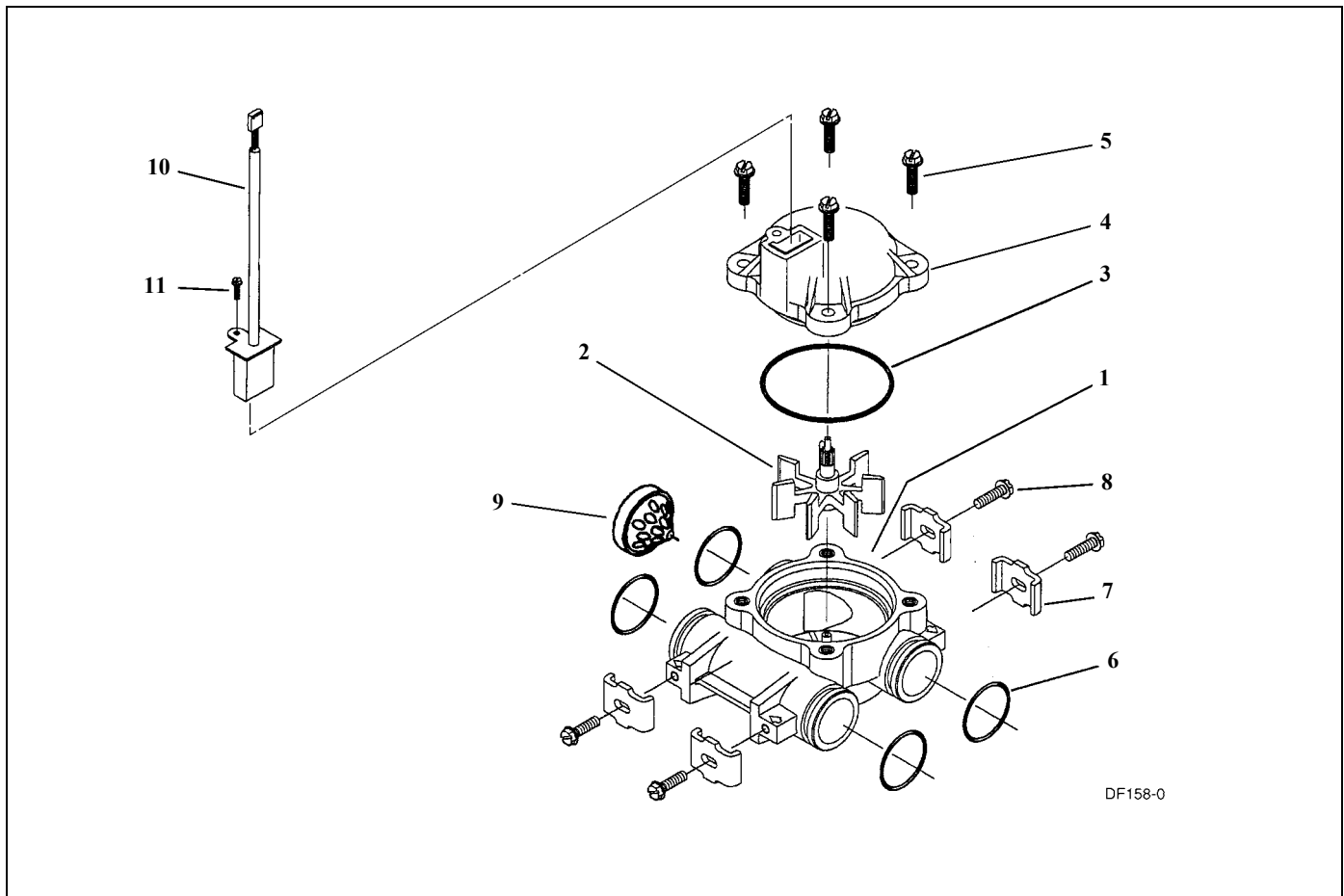

Figure 17: Meter Assembly

<i>Item Number</i>	<i>No. Req'd</i>	<i>Part Number</i>	<i>Description</i>
1	1	13821	meter body
2	1	13509	impeller
3	1	13847	o-ring, 137
4	1	14716	meter cap assembly, electronic
5	4	12473	screw, hex washer #10-24 x 5/8
6	4	13305	o-ring, 119
7	4	13255	clip, mounting
8	4	13314	screw, hex washer head #8-18 x 5/8
9	1	14613	flow straightener
10	1	19121-01	harness assembly, flow meter
11	1	17798	screw

Model 6600 Downflow

Bypass Valve Assembly, Plastic

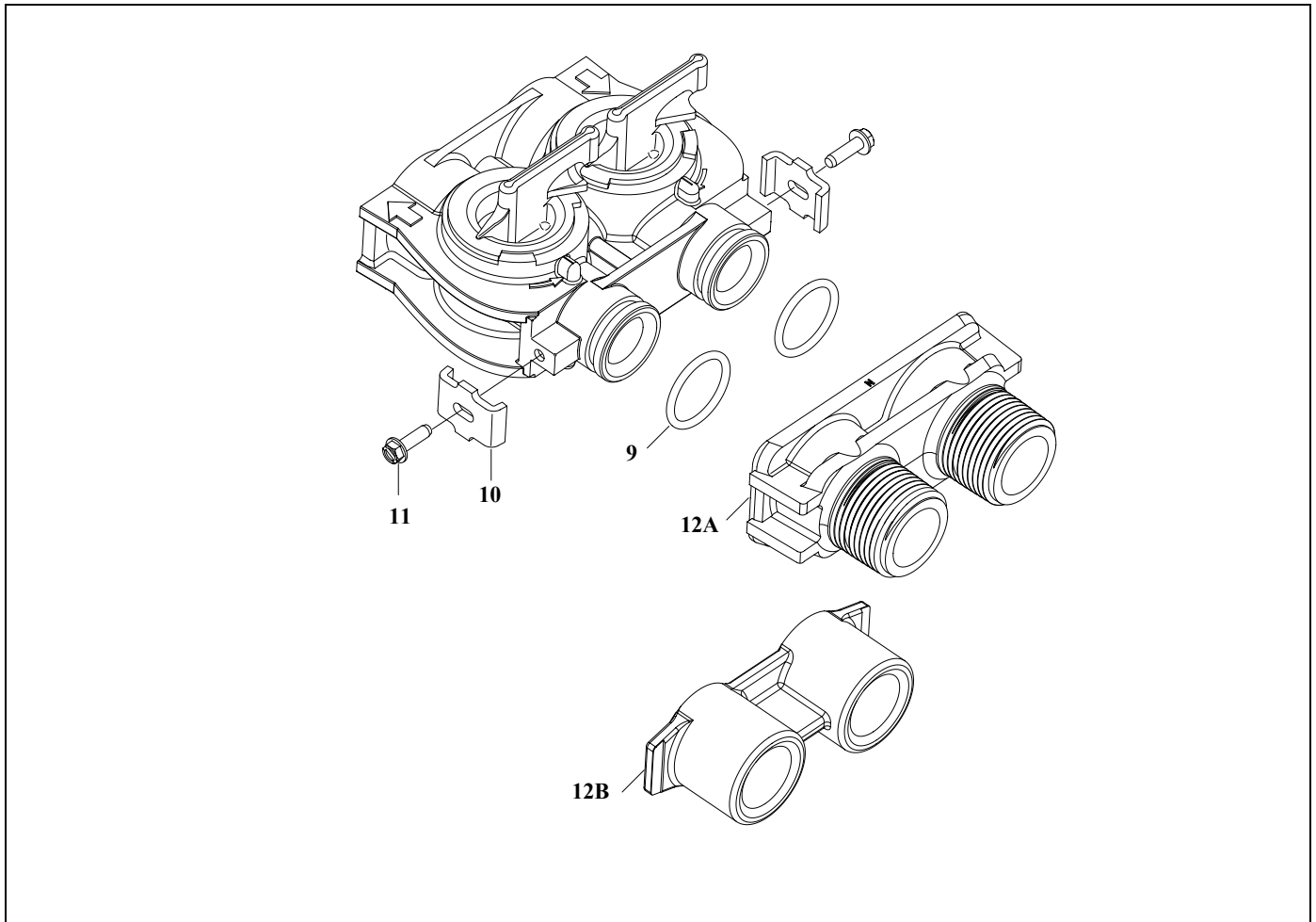

Figure 18: Bypass Valve Assembly, Plastic

Item Number	No. Req'd	Part Number	Description
9	2	13305	o-ring, 119
10	2	13255	clip, mounting
11	2	13314	screw, hex washer head, 8-18 x 5/8
12A	1	18706	yoke, plastic, 1" NPT
		18706-02	yoke, plastic, 3/4" NPT
12B	1	13708	yoke, brass, 3/4" NPT
	1	13708NP	yoke, 3/4" NPT nickel plated
	1	13398	yoke, brass, 1" NPT
	1	13398NP	yoke, 1" NPT nickel plated

Model 6600 Downflow

Bypass Valve Assembly, Brass

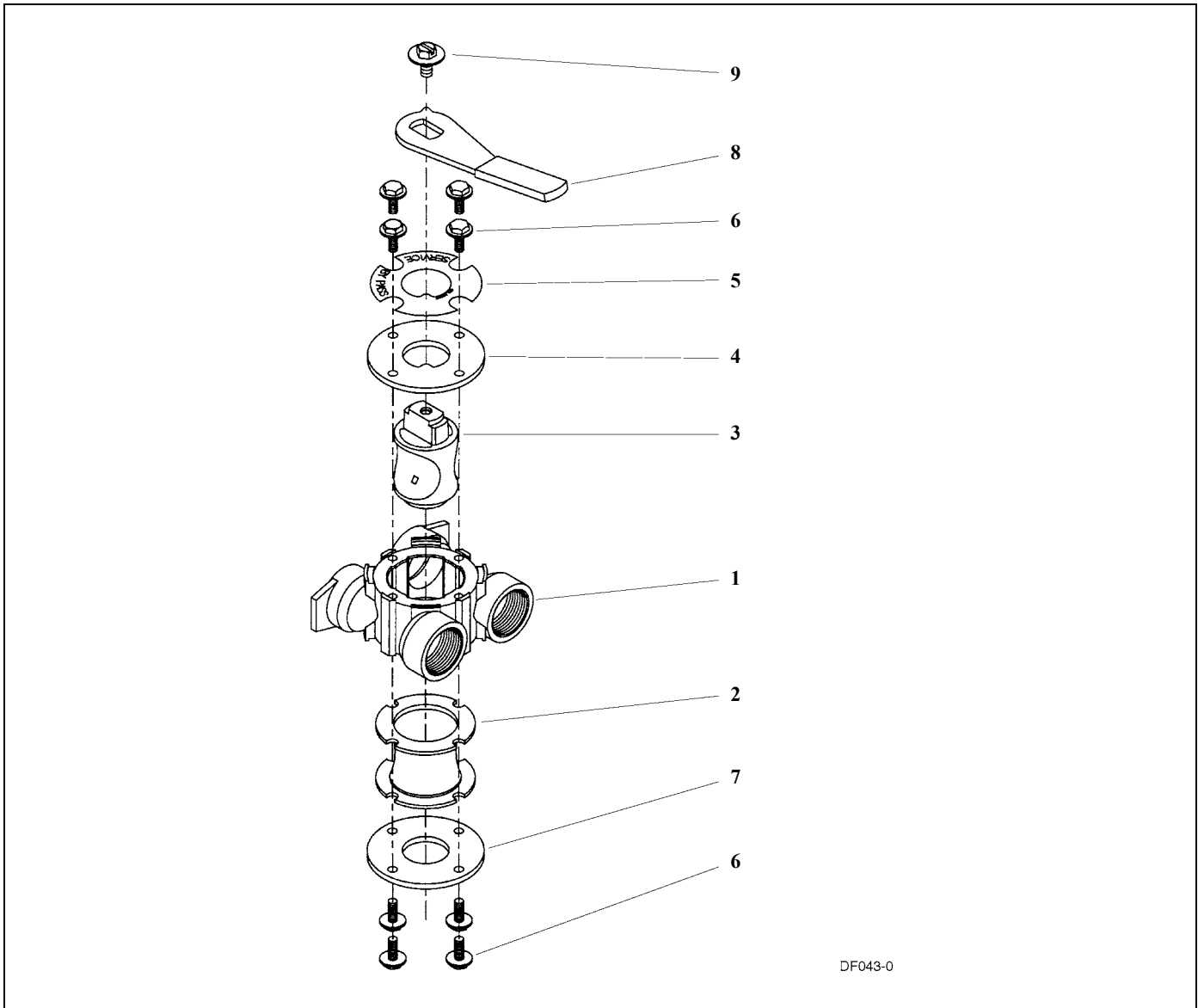

Figure 19: Bypass Valve Assembly, Brass

<i>Item Number</i>	<i>No. Req'd</i>	<i>Part Number</i>	<i>Description</i>
1	1	17290	bypass valve body, 3/4"
	1	17290NP	bypass valve body, 3/4" nickel plated
	1	13399	bypass valve body, 1"
	1	13399NP	bypass valve body, 1", nickel plated
2	1	11726	seal, bypass
3	1	11972	plug, bypass
4	1	11978	side cover
5	1	13604-01	label
6	8	15727	screw
7	1	11986	side cover
8	1	11979	lever, bypass
9	1	11989	screw, hex head, 1/4-14

Model 6600 Downflow

2300 Safety Brine Valve

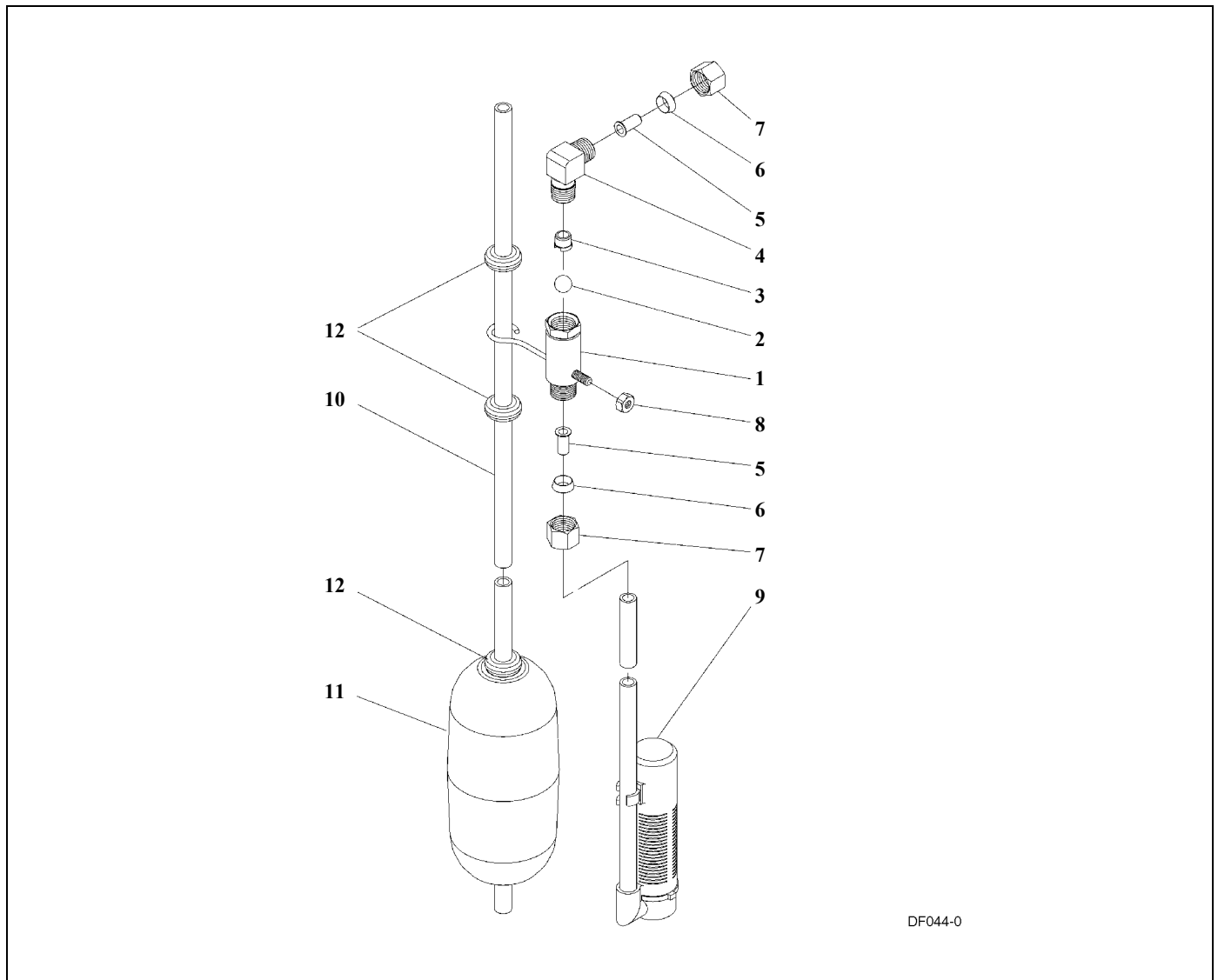
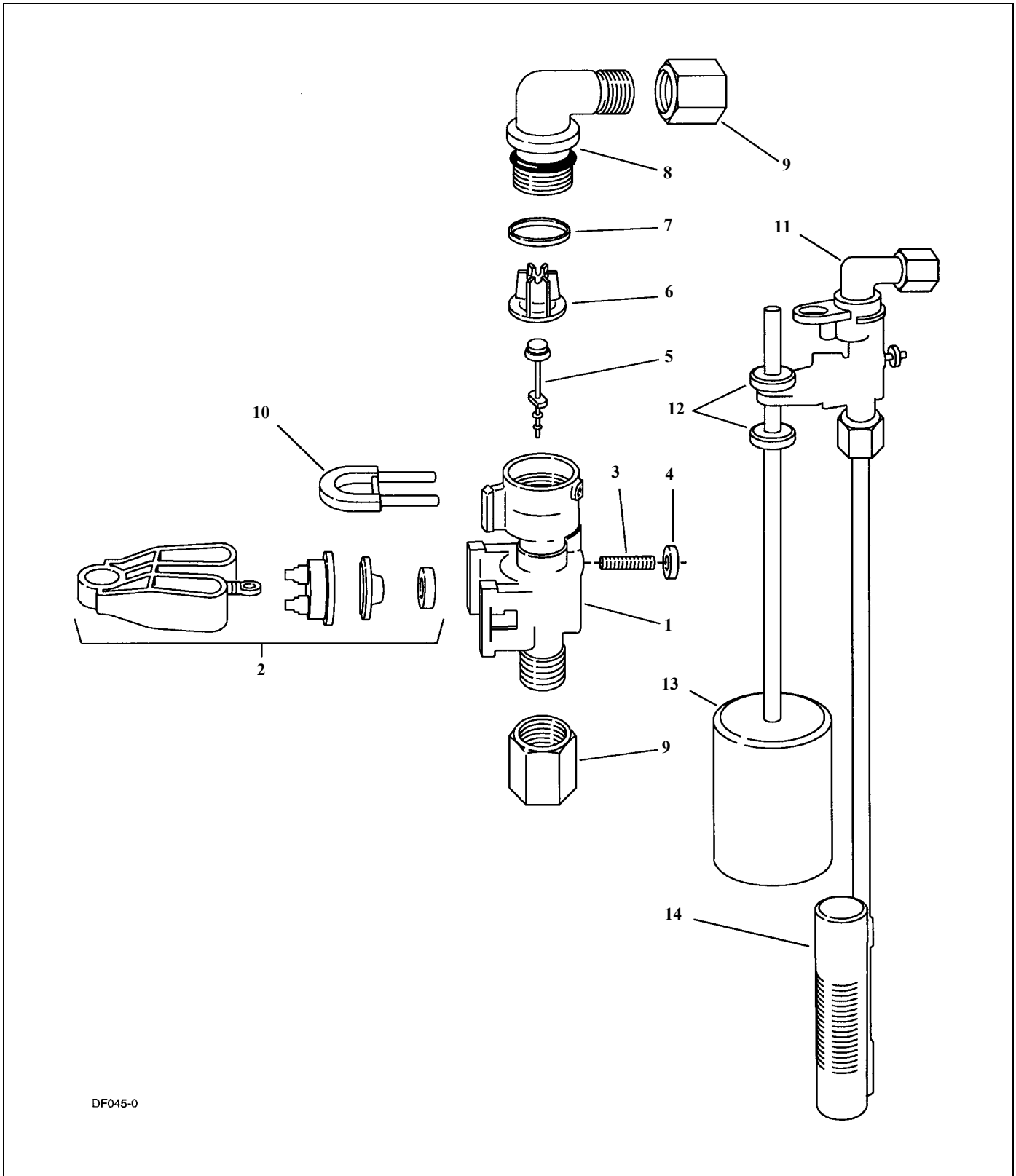

Figure 20: 2300 Safety Brine Valve

Item Number	No. Req'd	Part Number	Description
1	1	60027-00	2300 safety brine valve body
2	1	10138	ball, 3/8"
3	1	11566	bull stop
4	1	10328	elbow, 1/4" x 1/4" T
5	2	10332	insert, 3/8"
6	2	10330	sleeve, 3/8"
7	2	10329	tube nut, 3/8"
8	1	10186	nut, hex, 10-32, nylon
9	1	60002	#500 air check
10	1	10149	float rod, 30"
11	1	10700	float assembly, blue/white
12	4	10150	grommet

Model 6600 Downflow

2310 Safety Brine Valve



DF045-0

Figure 21: 2310 Safety Brine Valve

Model 6600 Downflow

2310 Safety Brine Valve (Cont'd.)

<i>Item Number</i>	<i>No. Req'd</i>	<i>Part Number</i>	<i>Description</i>
1	1	19645	safety brine valve body
2	1	19803	safety brine valve arm assembly
3	1	19804	stud, 10-24
4	1	19805	nut, 10-24
5	1	19652-01	poppet and seal
6	1	19649	flow dispenser
7	1	11183	o-ring, 017
8	1	19647	elbow, safety brine valve
9	2	19625	nut assembly, 3/8
10	1	18312	retaining clip
11	1	60014	safety brine valve, 2310 (includes items 1-10)
12	2	10150	grommet (included with item 13)
13	1	60068	float assembly, 2310
14	1	60002	500 air check assembly

Model 6600 Downflow

Valve Wiring Diagram

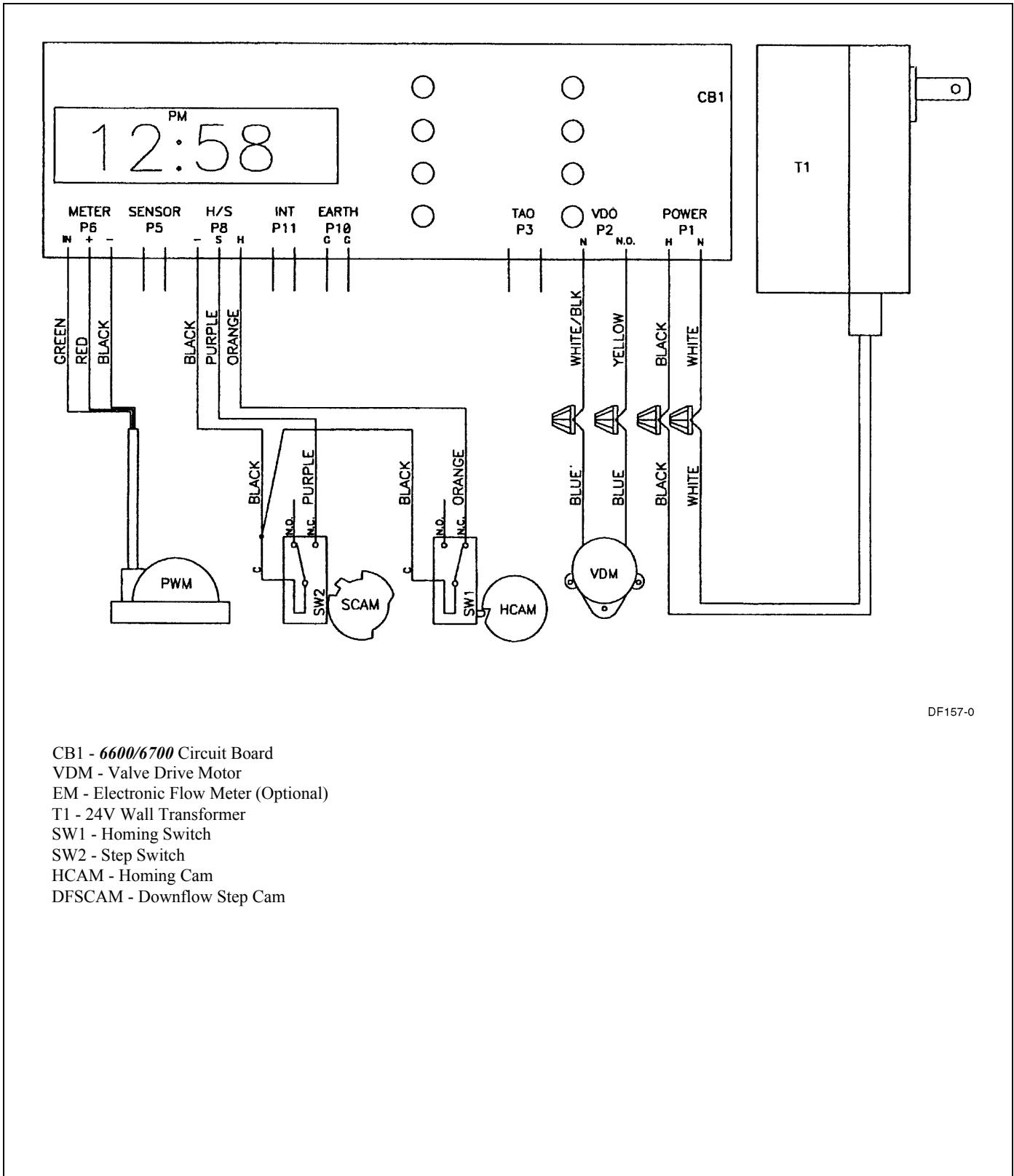

DF157-0

- CB1 - 6600/6700 Circuit Board
- VDM - Valve Drive Motor
- EM - Electronic Flow Meter (Optional)
- T1 - 24V Wall Transformer
- SW1 - Homing Switch
- SW2 - Step Switch
- HCAM - Homing Cam
- DFSCAM - Downflow Step Cam

Figure 22: Valve Wiring Diagram

Model 6600 Downflow

Service Instructions

Brine Valve, Injectors and Screen Replacement

1. Turn off water supply to conditioner:
 - a. If the conditioner installation has a “three valve” bypass system, first open the valve in the bypass line, then close the valves at the conditioner inlet and outlet.
 - b. If the conditioner has an integral bypass valve, put it in the **Bypass** position.
 - c. If there is only a shut-off valve near the conditioner inlet, close it.
2. Relieve water pressure in the conditioner by stepping the control into the **Backwash** position momentarily. Return the control to the **In Service** position.
3. Unplug electrical cord from outlet.
4. Disconnect brine tube and drain line connections at the injector body.
5. Remove the two injector body mounting screws. The injector and brine module can now be removed from the control valve. Remove and discard brine body o-rings.

Brine Valve Replacement

1. Pull brine valve from injector body. Also remove and discard o-ring at bottom of brine valve hole.
2. Apply silicone lubricant to new o-ring and reinstall at bottom of brine valve hole.
3. Apply silicone lubricant to o-ring on new valve assembly and press into brine valve hole. Be sure shoulder on bushing is flush with injector body.

Injectors/Screen Replacement

1. Remove injector cap and screen, discard o-ring. Unscrew injector nozzle and throat from injector body.
2. Screw in new injector throat and nozzle, be sure they are sealed tightly. Install a new screen.
3. Apply silicone lubricant to new o-ring and install around oval extension on injector cap.
4. Apply silicone lubricant to three new o-rings and install over three bosses on injector body.
5. Insert screws thorough injector cap and injector. Place this assembly thorough hole in timer housing and into mating holes in the valve body. Tighten screws.
6. Reconnect brine tube and drain line.
7. Return bypass or inlet valving to normal **In Service** position. Water pressure automatically builds in the conditioner.
NOTE: Be sure to shut off any bypass line.
8. Check for leaks at all seal areas. Check drain seal with the control in the **Backwash** position.
9. Plug electrical cord into outlet.
10. Set **Time Of Day** and cycle the control valve manually to assure proper function. Make sure control valve is returned to the **In Service** position.
11. Be sure there is enough salt in the brine tank.
12. Start regeneration cycle manually if water is hard.

Model 6600 Downflow

Service Instructions (Cont'd.)

Timer Replacement

To replace timer refer to *Brine Valve, Injectors and Screen Replacement*, steps 1–3.

1. Remove the control valve back cover. Remove the control valve front cover. Disconnect the meter dome signal wire from the front cover and feed it back through the control.
2. Remove screw and washer at drive yoke. Remove timer mounting screws. The entire timer assembly then lifts off easily.
3. Put new timer on top of valve. Be sure drive pin on main gear engages slot in drive yoke.
4. Replace timer mounting screws. Replace screw and washer at drive yoke. Replace meter signal wire.
5. Return bypass or inlet valving to normal **In Service** position. Water pressure automatically builds in the conditioner.

NOTE: Be sure to shut off any bypass line.

6. Replace the control valve back cover.
7. Follow *Injectors/Screen Replacement*, steps 9–12.

Piston Assembly Replacement

To replace piston assembly refer to *Brine Valve, Injectors and Screen Replacement*, steps 1–3.

1. Remove the control valve back cover. Remove the control valve front cover. Disconnect the meter dome signal wire from the front cover and feed it back through the control.
2. Remove screw and washer at drive yoke. Remove timer mounting screws. The entire timer assembly will now lift off easily. Remove end plug retainer plate.
3. Pull upward on end of piston yoke until assembly is out of valve.
4. Inspect the inside of the valve to make sure that all spacers and seals are in place, and that there is no foreign matter that would interfere with the valve operation.
5. Take new piston assembly as furnished and push piston into valve by means of the end plug. Twist yoke carefully in a clockwise direction to properly align it with drive gear. Replace end plug retainer plate.
6. Place timer on top of valve. Be sure drive pin on main gear engages slot in drive yoke.
7. Replace timer mounting screws. Replace screw and washer at drive yoke.
8. Return bypass or inlet valving to normal **In Service** position. Water pressure automatically builds in the conditioner.

NOTE: Be sure to shut off any bypass line.

9. Replace the control valve back cover.
10. Follow *Injectors/Screen Replacement*, steps 9–12.

Model 6600 Downflow

Service Instructions (Cont'd.)

Seal and Spacer Replacement

To replace seals and spacers, refer to *Brine Valve, Injectors and Screen Replacement*, steps 1–3.

1. Remove the control valve back cover. Remove the control valve front cover. Disconnect the meter dome signal wire from the front cover and feed it back through the control.
2. Remove screw and washer at drive yoke. Remove timer mounting screws. The entire timer assembly will now lift off easily. Remove end plug retainer plate.
3. Pull upward on end of piston rod yoke until assembly is out of valve. Remove and replace seals and spacers.
4. Take piston assembly and push piston into valve by means of the end plug. Twist yoke carefully in a clockwise direction to properly align it with drive gear. Replace end plug retainer plate.
5. Place timer on top of valve. Be sure drive pin on main gear engages slot in drive yoke.
6. Replace timer mounting screws. Replace screw and washer at drive yoke.
7. Return bypass or inlet valving to normal **In Service** position. Water pressure automatically builds in the conditioner.
NOTE: Be sure to shut off any bypass line.
8. Replace the control valve back cover.
9. Follow *Injectors/Screen Replacement*, steps 9–12.

Meter Replacement

To replace meter refer to *Brine Valve, Injectors and Screen Replacement*, steps 1–3.

1. Remove screw holding signal wire from meter dome.
2. Remove two screws and clips at bypass valve or yoke. Pull resin tank away from plumbing connections.
3. Remove two screws and clips at control valve. Pull meter module out of control valve.
4. Apply silicone lubricant to four new o-rings and assemble to four ports on new meter module.
5. Assemble meter to control valve.
NOTE: Meter portion of module must be assembled at valve outlet.
6. Attach two clips and screws at control valve. Be sure clip legs are firmly engaged with lugs.
7. Push resin tank back to the plumbing connections and engage meter ports with bypass valve or yoke.
8. Attach two clips and screws at bypass valve or yoke. Be sure clip legs are firmly engaged with lugs.
9. Return bypass or inlet valving to normal **In Service** position. Water pressure automatically builds in the conditioner.
NOTE: Be sure to shut off any bypass line.
10. Check for leaks at all seal areas.
11. Connect meter dome signal wire.
12. Follow *Injectors/Screen Replacement*, steps 9–12.

Model 6600 Downflow

Meter Cover/Impeller Replacement

To replace meter cover and/or cover, refer to *Brine Valve, Injectors and Screen Replacement*, steps 1–3.

1. Remove screw holding signal wire to meter dome.
2. Remove four screws from cover and lift cover off meter module. Discard o-ring.
3. Remove and inspect impeller for gear or spindle damage, replace if necessary.
4. Apply silicone lubricant to new o-ring and assemble to the smallest diameter on meter cover.
5. Assemble cover to meter module. Be sure impeller spindle enters freely into cover. Press firmly on cover and rotate if necessary to assist in assembly.
6. Replace four screws and tighten.
7. Return bypass or inlet valving to normal **In Service** position. Water pressure automatically builds in the conditioner.
NOTE: Be sure to shut off any bypass line.
8. Check for leaks at all seal areas.
9. Connect meter dome signal wire.
10. Follow *Injectors/Screen Replacement*, steps 9–12.

Model 6600 Downflow

Troubleshooting

PROBLEM	CAUSE	CORRECTION
1. Softener fails to regenerate.	<ul style="list-style-type: none"> A. Electrical service to unit has been interrupted. B. Timer is not operating properly. C. Defective valve drive motor. D. Timer programming bad (improper programming). 	<ul style="list-style-type: none"> A. Assure permanent electrical service (check fuse, plug, pull chain or switch). B. Replace timer. C. Replace drive motor. D. Check programming and reset as needed.
2. Softener delivers hard water.	<ul style="list-style-type: none"> A. Bypass valve is open. B. No salt in brine tank. C. Injectors or screen plugged. D. Insufficient water flowing into brine tank. E. Hot water tank hardness. F. Leak at distributor tube. G. Internal valve leak. H. Flow meter jammed. I. Flow meter cable disconnected or not plugged into meter cap. J. Improper programming. 	<ul style="list-style-type: none"> A. Close bypass valve. B. Add salt to brine tank and maintain salt level above water level. C. Replace injectors and screen. D. Check brine tank fill time and clean brine line flow control if plugged. E. Repeated flushings of the hot water tank is required. F. Make sure distributor tube is not cracked. Check o-ring and tube pilot. G. Replace seals and spacers and/or piston. H. Remove obstruction from flow meter. I. Check meter cable connection to timer and meter cap. J. Reprogram the control to the proper regeneration type, inlet water hardness, capacity or flow meter size.
3. Unit uses too much salt.	<ul style="list-style-type: none"> A. Improper salt setting. B. Excessive water in brine tank. C. Improper programming. 	<ul style="list-style-type: none"> A. Check salt usage and salt setting. B. See problem 7, page 32. C. Check programming and reset as needed.
4. Loss of water pressure.	<ul style="list-style-type: none"> A. Iron buildup in line to water conditioner. B. Iron buildup in water conditioner. C. Inlet of control plugged due to foreign material broken loose from pipes by recent work done on plumbing system. 	<ul style="list-style-type: none"> A. Clean line to water conditioner. B. Clean control and add resin cleaner to resin bed. Increase frequency of regeneration. C. Remove piston and clean control.
5. Loss of resin through drain line.	<ul style="list-style-type: none"> A. Air in water system. B. Drain line flow control is too large. 	<ul style="list-style-type: none"> A. Assure that well system has proper air eliminator control check for dry well condition. B. Ensure drain line flow control is sized correctly.
6. Iron in conditioned water.	<ul style="list-style-type: none"> A. Fouled resin bed. B. Iron content exceeds recommended parameters. 	<ul style="list-style-type: none"> A. Check backwash, brine draw and brine tank fill. Increase frequency of regeneration. Increase backwash time. B. Add iron removal from filter or system.

Model 6600 Downflow

Troubleshooting (Cont'd.)

PROBLEM	CAUSE	CORRECTION
7. Excessive water in brine tank.	A. Plugged drain line flow control. B. Brine valve failure. C. Improper programming.	A. Clean flow control. B. Replace brine valve. C. Check programming and reset as needed.
8. Salt water in service line.	A. Plugged injector system. B. Timer not operating properly. C. Foreign material in brine valve. D. Foreign material in brine line flow control. E. Low water pressure. F. Improper programming.	A. Clean injector and replace screen. B. Replace timer. C. Clean or replace brine valve. D. Clean brine line flow control. E. Raise water pressure. F. Check programming and reset as needed.
9. Softener fails to draw brine.	A. Drain line flow control is plugged. B. Injector is plugged. C. Injector screen plugged. D. Line pressure is too low. E. Internal control leak. F. Improper programming. G. Timer not operating properly.	A. Clean drain line flow control. B. Clean or replace injectors. C. Replace screen. D. Increase line pressure (line pressure must be at least 25 psi at all times.) E. Change seals and spacers and/or piston assembly. F. Check programming and reset as needed. G. Replace timer.
10. Control cycles continuously.	A. Timer not operating properly. B. Faulty microswitches and or harness. C. Faulty cycle cam operation.	A. Replace timer. B. Replace faulty microswitch or harness. C. Replace cycle cam or reinstall.
11. Drain flows continuously.	A. Foreign material in control. B. Internal control leak. C. Control valve jammed in brine or backwash position. D. Timer motor stopped or jammed. E. Timer not operating properly.	A. Remove piston assembly and inspect bore, remove foreign material and check control in various regeneration positions. B. Replace seals and/or piston assembly. C. Replace piston and seals and spacers. D. Replace timer motor and check all gears for missing teeth. E. Replace timer.

Model 6600 Downflow

Service Assemblies

	60022-12	BLFC .125 gpm
	60022-25	BLFC .25 gpm
	60022-50	BLFC .50 gpm
	60022-100	BLFC 1.0 gpm
		<i>For illustration see Figure 15, page 16.</i>
1	17307	flow washer .125 gpm
	12094	flow washer .25 gpm
	12095	flow washer .50 gpm
	12097	flow washer 1.0 gpm
1	12977	o-ring, 015
1	13244	adapter, BLFC
1	13245	retainer, BLFC
	60032	brine valve
		<i>For illustration see Figure 15, page 16.</i>
1	11973	spring, brine valve
1	11981-01	retaining ring
1	12550	quad ring, 009
1	13165	cap, brine valve
1	13167	spacer, brine valve
2	13302	o-ring, 014
1	16098	washer, plain, nylon
1	13172	brine valve stem
1	12626	seat, brine valve
	60040	bypass, 3/4", brass
	60040NP	bypass, 3/4", nickel
	60041	bypass, 1", brass
	60041NP	bypass, 1", nickel
		<i>For illustration see Figure 19, page 22.</i>
	60049	bypass, plastic, 3/4"
		<i>For illustration see Figure 18, page 21.</i>
	60102-71	6600 piston assembly, downflow
		<i>For illustration see Figure 15, page 16.</i>
1	14309	piston rod retainer
1	13001-04	piston rod assembly
1	13446-40	end plug assembly, green
1	17218	piston, downflow rapid rinse
	60125	6600 seal and spacer kit
		<i>For illustration see Figure 15, page 16.</i>
5	13242	seal
4	14241	spacer
	60084	injector, module assembly
		(Specify injector number, DLFC size, BLFC size)
		<i>For illustration see Figure 15, page 16.</i>
	60086-50	6600 meter assembly
		<i>For illustration see Figure 17, page 20.</i>
	60751-121	6600 front panel assembly
		24V 50/60Hz, black, 1 relay
		<i>For illustration see Figure 16, page 18.</i>

Model 6600 Downflow

Notes:
